

HONDA CBR1000F OWNER'S MANUAL

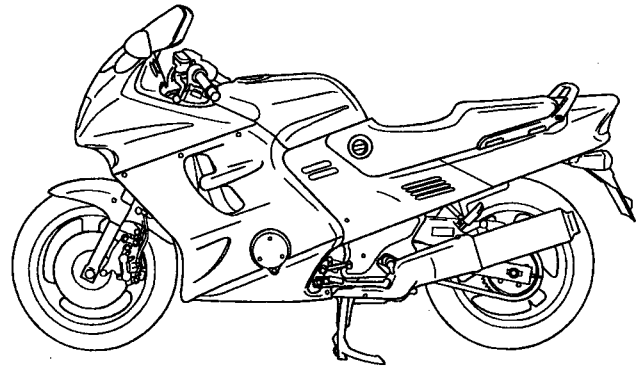

**All information in this publication is based on the latest production information available at the time of approval for printing. HONDA MOTOR CO.,LTD. reserves the right to make changes at any time without notice and without incurring any obligation.
No part of this publication may be reproduced without written permission.**

WELCOME

The motorcycle presents you a challenge to master the machine, a challenge to adventure. You ride through the wind, linked to the road by a vehicle that responds to your commands as no other does. Unlike an automobile, there is no metal cage around you. Like an airplane, a pre-ride inspection and regular maintenance are essential to your safety. Your reward is freedom.

To meet the challenges safely, and to enjoy the adventure fully, you should become thoroughly familiar with this owner's manual BEFORE YOU RIDE THE MOTORCYCLE.

When service is required, remember that your Honda dealer knows your motorcycle best. If you have the required mechanical "know-how" and tools, your dealer can supply you with an official Honda Service Manual to help you perform many maintenance and repair tasks.

Pleasant riding, and thank you for choosing a Honda !

- The illustrations and photos herein are based on the ED type.
- Following codes in this manual indicate each country.

ED	European direct sales	E	UK	ND	Finland
	Belgium	F	France		Norway
	Holland	U	Australia		Denmark
	Portugal	SW	Switzerland	IT	Italy
G	Germany	AR	Austria	SP	Spain
	Sweden				

- The specifications may vary with each locale.

OPERATION

Page		Page	
1	MOTORCYCLE SAFETY	33	Right Handlebar Controls
1	Safe Riding Rules	35	Left Handlebar Controls
2	Protective Apparel		
2	Modifications	36	FEATURES (Not required for operation)
3	Loading and Accessories	36	Steering Lock
		37	Helmet Holder
6	PARTS LOCATION	38	Seat
9	Instruments and Indicators	39	Document Compartment
14	MAJOR COMPONENTS (Information you need to operate this motorcycle)	39	Cord Hook
14	Suspension	40	Side Cover
17	Brakes	41	Lower Fairing
21	Clutch		
22	Coolant	43	OPERATION
24	Fuel	43	Pre-ride Inspection
28	Engine Oil	44	Starting the Engine
29	Tubeless Tyres	47	Running-in
		48	Riding
32	ESSENTIAL INDIVIDUAL COMPONENTS	49	Braking
32	Ignition Switch	51	Parking
		52	Anti-theft Tips

MAINTENANCE

Page

53	MAINTENANCE
54	Maintenance Schedule
56	Tool Kit
57	Serial Numbers
58	Colour Label
59	Maintenance Precautions
60	Air Cleaner
62	Crankcase Breather
63	Engine Oil
67	Spark Plugs
70	Throttle Operation
71	Idle Speed
72	Drive Chain
77	Drive Chain Slider
77	Front and Rear Suspension
78	Side Stand
79	Wheel Removal

page

87	Brake Pad Wear
89	Brake System Inspection
90	Battery
93	Fuse Replacement
95	Stoplight Switch Adjustment
96	Bulb Replacement
102	CLEANING
104	STORAGE GUIDE
104	Storage
105	Removal from Storage
106	NOISE CONTROL SYSTEM (AUSTRALIA ONLY)
107	SPECIFICATIONS

MOTORCYCLE SAFETY

▲ WARNING

*** Motorcycle riding requires special efforts on your part to ensure your safety. Know these requirements before you ride:**

SAFE RIDING RULES

1. Always make a pre-ride inspection (page 43) before you start the engine. You may prevent an accident or equipment damage.
2. Many accidents involve inexperienced riders. Most countries require a special motorcycle riding test or license. Make sure you are qualified before you ride. NEVER lend your motorcycle to an inexperienced rider.
3. Many automobile/motorcycle accidents happen because the automobile driver does not "see" the motorcyclist. Make yourself conspicuous to help avoid the accident that wasn't your fault:
 - Wear bright or reflective clothing.
 - Don't ride in another motorist's "blind spot."
4. Obey all national and local laws and regulations.
 - Excessive speed is a factor in many accidents. Obey the speed limits, and NEVER travel faster than conditions warrant.
 - Signal before you make a turn or lane change. Your size and maneuverability can surprise other motorists.
5. Don't let other motorists surprise you. Use extra caution at intersections, parking lot entrances and exits, and driveways.
6. Keep both hands on the handlebars and both feet on the footpegs while riding. A passenger should hold on to the motorcycle or the operator with both hands and keep both feet on the passenger footpegs.

PROTECTIVE APPAREL

1. Most motorcycle accident fatalities are due to head injuries: **ALWAYS** wear a helmet. You should also wear a face shield or goggles as well as boots, gloves and protective clothing. A passenger needs the same protection.
2. The exhaust system becomes hot during operation, and it remains hot for a while after stopping the engine. Be careful not to touch the exhaust system while it is hot. Wear clothing that fully covers your legs.
3. Do not wear loose clothing which could catch on the control levers, footpegs, drive chain or wheels.

MODIFICATIONS

▲ WARNING

*** Modification of the motorcycle, or removal of original equipment, may render the vehicle unsafe or illegal. Obey all national and local equipment regulations.**

LOADING AND ACCESSORIES

▲ WARNING

*** To prevent an accident, use extreme care when adding and riding with accessories and cargo. Addition of accessories and cargo can reduce a motorcycle's stability, performance and safe operating speed. Never ride an accessory-equipped motorcycle at speeds above 130 km/h (80 mph). And remember that this 130 km/h (80 mph) limit may be reduced by installation of non-Honda accessories, improper loading, worn tyres and overall motorcycle condition, poor road or weather conditions. These general guidelines may help you decide whether or how to equip your motorcycle and how to load it safely.**

Loading

The combined weight of the rider, passenger, cargo and additional accessories must not exceed the maximum weight capacity:
185 kg (408 lbs)

Cargo weight alone should not exceed:
30 kg (66 lbs)

1. Keep cargo and accessory weight low and close to the center of the motorcycle. Load weight equally on both sides to minimize imbalance. As weight is located further from the motorcycle's center of gravity, handling is proportionally affected.
2. Adjust tyre pressure (page 29) and rear suspension (page 14) to suit load weight and riding conditions.

3. Vehicle handling and stability can be adversely affected by loose cargo. Recheck cargo security and accessory mounts frequently.
4. The Honda fairing is designed for this motorcycle only. Do not install it on any other motorcycle.
5. Do not attach large or heavy items (such as a sleeping bag or tent) to the handlebars, fork, or fender. Unstable handling or slow steering response may result.

Accessories

Genuine Honda accessories have been specifically designed for and tested on this motorcycle. Because the factory cannot test all other accessories, you are personally responsible for proper selection, installation, and use of non-Honda accessories. Always follow the guidelines under Loading, and these:

1. Carefully inspect the accessory to make sure it does not obscure any lights, reduce ground clearance and banking angle, or limit suspension travel, steering travel or control operation.
2. Large fork-mounted fairings or windshields, or poorly designed or improperly mounted fairings can produce aerodynamic forces that cause unstable handling. Do not install fairings that decrease cooling air flow to the engine.

3. Accessories which alter your riding position by moving hands or feet away from controls may increase reaction time in an emergency.
4. Do not add electrical equipment that will exceed the motorcycle's electrical system capacity. A blown fuse could cause a dangerous loss of lights or engine power.
5. This motorcycle was not designed to pull a sidecar or trailer. Handling may be seriously impaired if so equipped.
6. Any modification of the cooling system may cause overheating and serious engine damage. Do not modify the radiator shrouds or install accessories which block or deflect air away from the radiator.

PARTS LOCATION

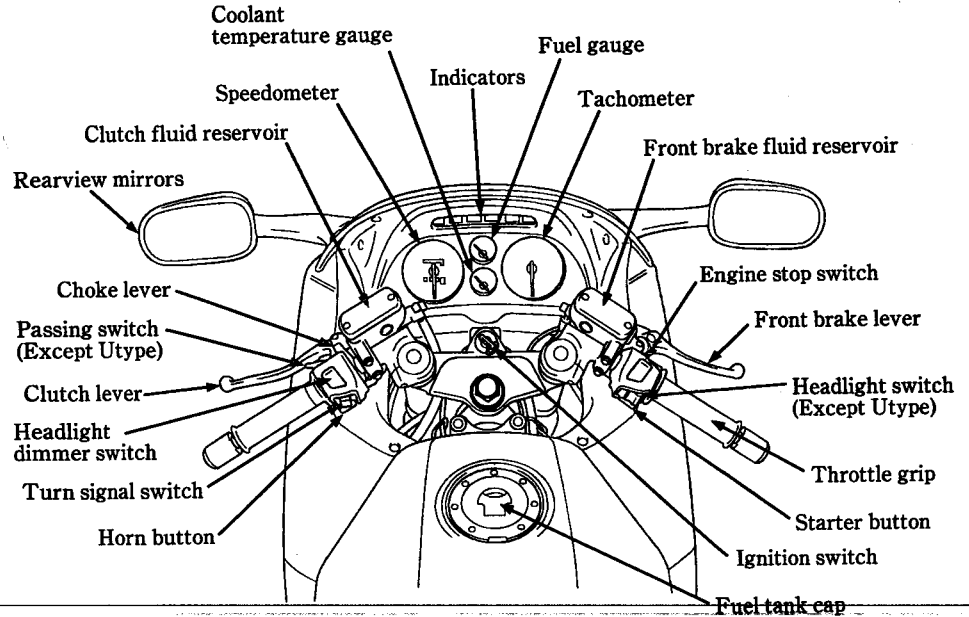

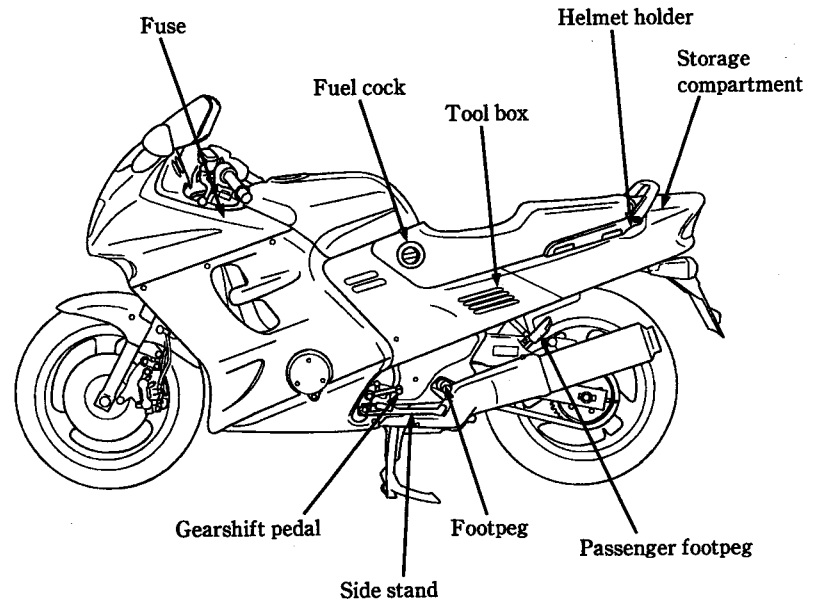

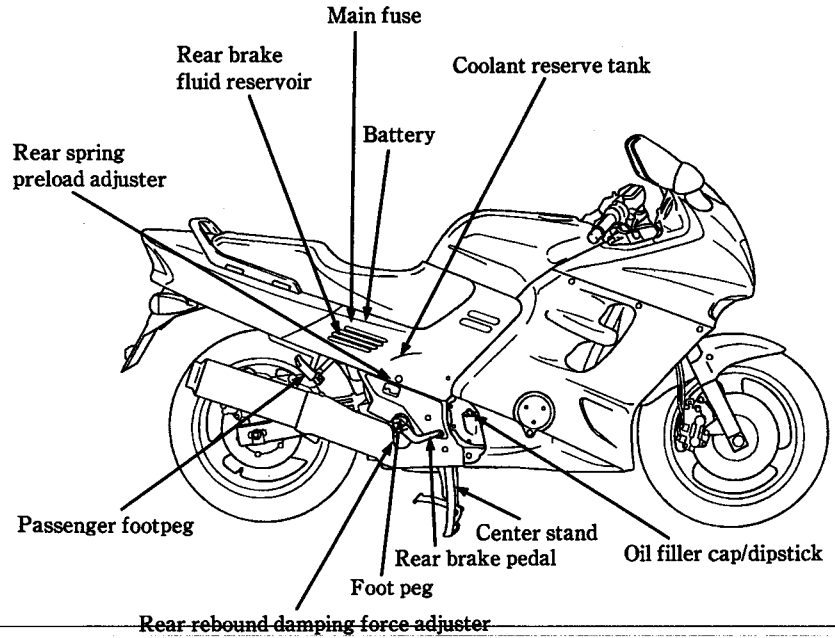

INSTRUMENTS AND INDICATORS

The indicators are contained in the instrument panel. Their functions are described in the tables on the following pages.

- (1) Speedometer
- (2) Tripmeter
- (3) Odometer
- (4) Left turn signal indicator
- (5) Low oil pressure indicator
- (6) Side stand indicator
- (7) Neutral indicator
- (8) High beam indicator
- (9) Right turn signal indicator
- (10) Tachometer
- (11) Tachometer red zone
- (12) Fuel gauge
- (13) Coolant temperature gauge
- (14) Tripmeter reset knob

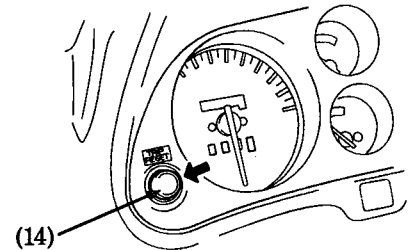
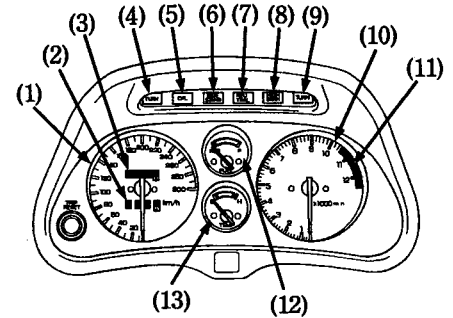

(Ref. No.) Description	Function
(1) Speedometer	Shows riding speed.
(2) Tripmeter	Shows mileage per trip.
(3) Odometer	Shows accumulated mileage.
(4) Left turn signal indicator	Flashes when the left turn signal operates.
(5) Low oil pressure indicator (red)	<p>Lights when engine oil pressure is below normal operating range. Should light when ignition switch is ON and engine is not running. Should go out when the engine starts, except for occasional flickering at or near idling speed when engine is warm.</p> <p>CAUTION: * Running the engine with insufficient oil pressure may cause serious engine damage.</p>
(6) Side stand indicator (amber)	Lights when the side stand is put down. Before parking, check that the side stand is fully down; the light only indicates the side stand ignition cut-off system (page 78) is activated.

(Ref. No.) Description	Function
(7) Neutral indicator (green)	Lights when the transmission is in neutral.
(8) High beam indicator (blue)	Light when the headlight is on high beam.
(9) Right turn signal indicator	Flashes when the right turn signal operates.
(10) Tachometer	Shows engine rpm.
(11) Tachometer red zone	Never allow the tachometer needle to enter the red zone, even after the engine has been broken in. CAUTION: * Running the engine beyond recommended maximum engine speed (tachometer red zone) can damage the engine.
(12) Fuel gauge	Shows approximate fuel supply available (see page 13).
(13) Coolant temperature gauge	Shows coolant temperature (see page 12).
(14) Tripmeter reset knob	Resets tripmeter to zero (0) by pushing the knob.

Coolant Temperature Gauge

When the needle begins to move above the C (Cold) mark, the engine is warm enough for the motorcycle to be ridden. The normal operating temperature range is within the section between the H and C marks. If the needle reaches the H (Hot) mark, stop the engine and check the reserve tank coolant level. Read pages 22 – 23 and do not ride the motorcycle until the problem has been corrected.

CAUTION:

* Exceeding maximum running temperature may cause serious engine damage.

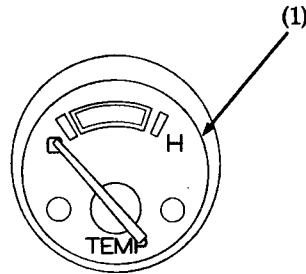

(1) Coolant temperature gauge

Fuel Gauge

The fuel gauge (1) shows the approximate fuel supply available. At F (Full), the fuel tank capacity including reserve is:

22.0 ℓ (5.81 US gal , 4.84 Imp gal)

When the gauge needle first points to RES, refill the tank as soon as possible. At RES there is :

3.5 ℓ (0.92 US gal , 0.77 Imp gal)

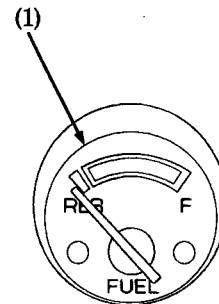

(1) Fuel gauge

MAJOR COMPONENTS (Information you need to operate this motorcycle)

▲ WARNING

*** If the Pre-ride Inspection (page 43) is not performed, severe personal injury or vehicle damage may result.**

SUSPENSION

Rear Suspension

The rear suspension can provide the desired ride under various rider/passenger weight and riding conditions through adjustments of the rebound damping and spring preload adjuster.

Rebound damping force adjustment :

The damping force adjuster (1) is located behind the right muffler protector.

To reduce damping force:
turn the adjuster counterclockwise.

To increase damping force:
turn the adjuster clockwise.

To adjust the adjuster to the standard position, proceed as follows :

1. Turn the damping adjuster (1) clockwise until it will no longer turn. This is the full hard setting.
2. The adjuster is set in the standard position when the adjuster is turned counterclockwise approximately 0.5 turn so that its punch mark (2) aligns with the reference punch mark (3).

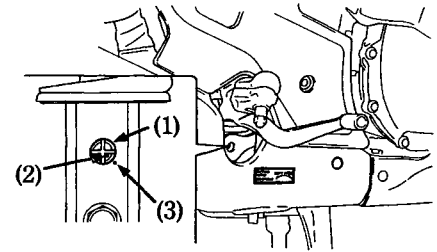

- (1) Rebound damping force adjuster
(2) Punch mark (3) Reference punch mark

Spring preload adjustment :

The spring preload adjuster (1) has 22 positions to turn it with a 8 mm box wrench and handle grip provided in the tool box.

The adjuster is located behind the right side cover.

The standard position: LOW

To reduce preload—turn the adjuster counterclockwise.

To increase preload—turn the adjuster clockwise.

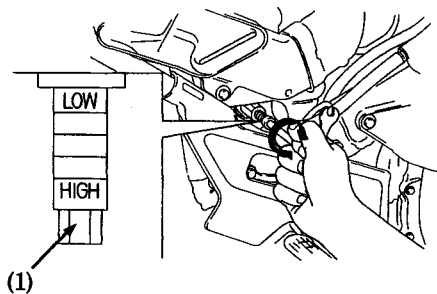

(1) Spring preload adjuster

▲ WARNING

- * **The rear shock absorber assembly includes a damper unit that contains high pressure nitrogen gas. The instructions found in this owner's manual are limited to adjustment of the shock assembly only. Do not attempt to disassemble, disconnect or service the damper unit; an explosion causing serious injury may result.**
- * **Puncture or exposure to flame may also result in an explosion, causing serious injury.**
- * **Service or disposal should only be done by your authorized Honda dealer or a qualified mechanic, equipped with the proper tools, safety equipment and the official Honda Shop Manual.**

BRAKES

Both the front and rear brakes are the hydraulic disc types.

As the brake pads wear, the brake fluid level drops.

There are no adjustments to perform, but fluid level and pad wear must be inspected periodically. The system must be inspected frequently to ensure there are no fluid leaks. If the control lever or pedal free travel becomes excessive and the brake pads are not worn beyond the recommended limit (page 87), there is probably air in the brake system and it must be bled. See your authorized Honda dealer for this service.

Front Brake Fluid Level:

▲ WARNING

- * **Brake fluid may cause irritation. Avoid contact with skin or eyes. In case of contact, flush thoroughly with water and call a doctor if your eyes were exposed.**
- * **KEEP OUT OF REACH OF CHILDREN.**

CAUTION:

- * **Handle brake fluid with care because it can damage plastic and painted surfaces.**
- * **When adding brake fluid, be sure the reservoir is horizontal before the cap is removed or brake fluid may spill out.**
- * **Use only DOT 4 brake fluid from a sealed container.**
- * **Never allow contaminants such as dirt or water to enter the brake fluid reservoir.**

Check that the fluid level is above the LOWER level mark (1) with the motorcycle in an upright position.

Brake fluid must be added to the reservoir whenever the fluid level begins to reach the LOWER level mark (1). Remove the screws (2), reservoir cover (3), diaphragm plate (4), diaphragm (5), and float (6). Fill the reservoir with DOT 4 BRAKE FLUID from a sealed container up to the upper level mark (7). Reinstall the float, diaphragm, diaphragm plate, and cover. Tighten the screws securely.

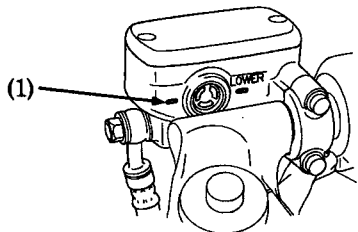

(1) LOWER level mark

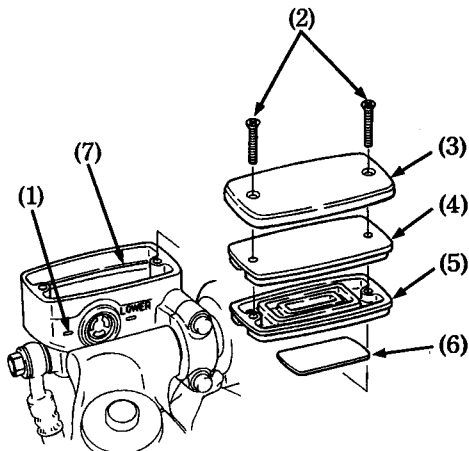

(2) Screws

(3) Reservoir cover

(4) Diaphragm plate

(5) Diaphragm

(6) Float

(7) Upper level mark

Front Brake Lever:

The distance between the tip of the brake lever (1) and the grip can be adjusted by turning the adjuster (2).

CAUTION:

- * Align the arrow (3) on the brake lever with index mark (4) on the adjuster.

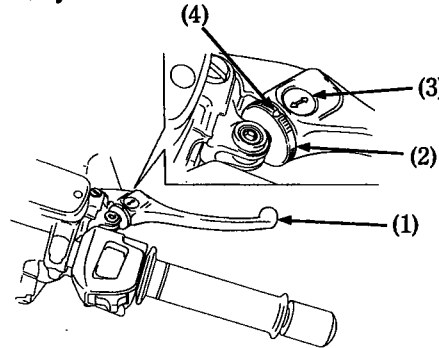

(1) Brake lever
(2) Adjuster

(3) Arrow
(4) Index mark

Rear brake fluid level:

▲ WARNING

- * Brake fluid may cause irritation. Avoid contact with skin or eyes. In case of contact, flush thoroughly with water and call a doctor if your eyes were exposed.
- * **KEEP OUT OF REACH OF CHILDREN.**

CAUTION:

- * Handle brake fluid with care because it can damage plastic and painted surfaces.
- * When adding brake fluid, be sure the reservoir is horizontal before the cap is removed or brake fluid may spill out.
- * Use only DOT 4 brake fluid from a sealed container.
- * Never allow contaminants such as dirt or water to enter the brake fluid reservoir.

Check the brake fluid level from the inspection window (1) of the right side cover with the motorcycle in an upright position.

Brake fluid must be added to the reservoir whenever the fluid level begins to reach the LOWER level mark (2). Remove the right side cover (page 40) and duct (page 51). Remove the bolt (3).

Remove the reservoir cap (4), diaphragm plate (5), and diaphragm (6). Fill the reservoir with DOT 4 BRAKE FLUID from a sealed container up to the UPPER level mark (7). Reinstall the diaphragm, diaphragm plate, cap and bolt securely.

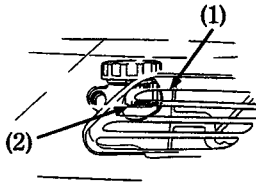

- (1) Inspection window
 - (2) LOWER level mark
- 20

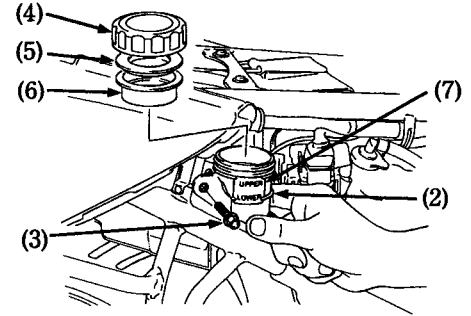

- (3) Bolt
- (4) Reservoir cap
- (5) Diaphragm plate
- (6) Diaphragm
- (7) UPPER level mark

Other Checks:

Make sure there are no fluid leaks. Check for deterioration or cracks in the hoses and fittings.

CLUTCH

This motorcycle has a hydraulically actuated clutch. There are no adjustments to perform but the clutch system must be inspected periodically for fluid level and leakage. If the control lever freeplay becomes excessive and the motorcycle creeps or stalls when shifted into gear, or if the clutch slips, causing acceleration to lag behind engine speed, there is probably air in the clutch system and it must be bled out. See your authorized Honda dealer for this service.

Fluid level:

Check that the fluid level is above the LOWER level mark (1) with the motorcycle in an upright position. If the fluid level is near the lower level line, it indicates fluid leakage. See your authorized Honda dealer.

Other Checks:

Make sure there are no fluid leaks. Check for deterioration or cracks in the hoses and fittings.

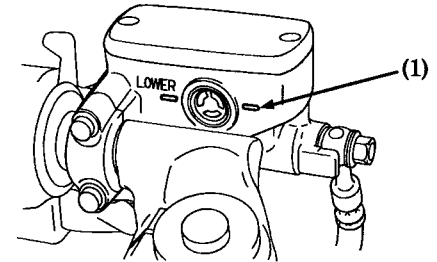

(1) LOWER level mark

COOLANT

Coolant Recommendation

The owner must properly maintain the coolant to prevent freezing, overheating, and corrosion. Use only high quality ethylene glycol antifreeze containing corrosion protection inhibitors specifically recommended for use in aluminum engines. (SEE ANTIFREEZE CONTAINER LABEL).

CAUTION:

*** Use only low-mineral drinking water or distilled water as a part of the antifreeze solution. Water that is high in mineral content or salt may be harmful to the aluminum engine.**

The factory provides a 50/50 solution of antifreeze and distilled water in this motorcycle. This coolant solution is recommended for most operating temperatures and provides good corrosion protection. A higher concentration of antifreeze decreases the cooling system performance and is recommended only when additional protection against freezing is needed. A concentration of less than 40/60 (40% antifreeze) will not provide proper corrosion protection. During freezing temperatures, check the cooling system frequently and add higher concentrations of antifreeze (up to a maximum of 60% antifreeze) if required.

Inspection

Remove the seat and right side cover.

Check the coolant level in the reserve tank (1) while the engine is at the normal operating temperature with the motorcycle in an upright position. If the coolant level is below the LOWER level mark (3), remove the reserve tank cap (4) and add coolant mixture until it reaches the UPPER level mark (2). Do not remove the radiator cap.

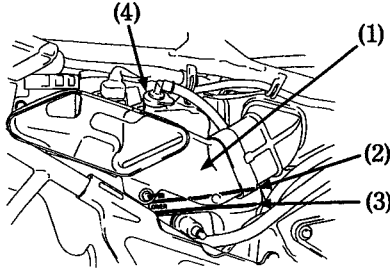

(1) Reserve tank (3) LOWER level mark
(2) UPPER level mark (4) Reserve tank cap

▲ WARNING

- * **Do not remove the radiator cap when the engine is hot. The coolant is under pressure and could scald you.**
- * **Keep hands and clothing away from the cooling fan, as it starts automatically.**

If the reserve tank is empty, or if coolant loss is excessive, check for leaks and see your authorized Honda dealer for repair.

FUEL

Manual Fuel Cock

The manual fuel cock (1) is under the left side of the fuel tank. Set it to ON for normal operation or RES when you start to run out of the main fuel supply. The OFF setting is only for long term storage or servicing of fuel system components.

Automatic Fuel ON-OFF

With the fuel cock set to ON (or RES) fuel flows to the carburetors only when the engine is being started or is running. A diaphragm shuts off fuel flow when the engine is turned off.

Reserve Fuel

When the main fuel supply is gone, turn the fuel cock to RES. Refill the tank as soon as possible after switching to RES, then switch the cock back to ON.

The reserve fuel supply is:

3.5 l (0.92 US gal , 0.77 Imp gal)

▲ WARNING

- * To avoid running out of fuel that may result in a sudden stop, learn how to operate the fuel cock when riding the motorcycle.

NOTE:

- * Remember to check that the fuel cock is in the ON position each time you refuel. If the cock is left in the RES position, you may run out of fuel with no reserve.

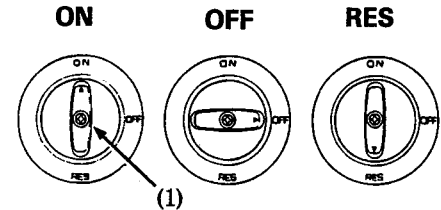

(1) Fuel cock

Fuel Tank

The fuel tank capacity including the reserve supply is:

22.0 l (5.81 US gal, 4.84 Imp gal)

To open the fuel tank cap (1), open the tank cap cover (2), insert the ignition key (3) and turn it clockwise. The cap will pop up and can be lifted off.

To close the fuel tank cap, align the latch in the cap with the solt in the filler neck. Push cap into the filler neck until it snaps closed and locks. Remove the key and close the tank cap cover.

Except AUSTRALIA:

Use unleaded or low-lead petrol with a research octane number of 91 or higher. We recommend that you use unleaded petrol because it produces fewer engine and spark plug deposits and extends the life of exhaust system components.

For AUSTRALIA only

Use unleaded petrol with a research octane number of 91 or higher.

CAUTION:

* If “spark knock” or “pinking” occurs at a steady engine speed under normal load, change brands of petrol. If spark knock or pinking persists, consult your authorized Honda dealer. Failure to do so is considered misuse, and damage caused by misuse is not covered by Honda’s Limited Warranty.

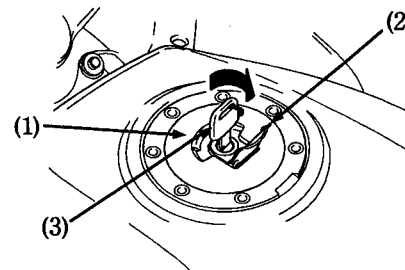

- (1) Fuel tank cap (3) Ignition key
(2) Tank cap cover

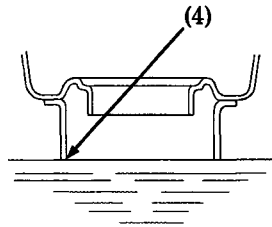

(4) Filler neck

▲ WARNING

- * **Petrol is extremely flammable and is explosive under certain conditions. Refuel in a well-ventilated area with the engine stopped. Do not smoke or allow flames or sparks in the area where petrol is stored or where the fuel tank is refueled.**
- * **Do not overfill the tank (there should be no fuel in the filler neck (4)). After refueling, make sure the fuel cap is closed securely.**
- * **Be careful not to spill fuel when refueling. Spilled fuel or fuel vapor may ignite. If any fuel is spilled, make sure the area is dry before starting the engine.**
- * **Avoid repeated or prolonged contact with skin or breathing of vapor. KEEP OUT OF REACH OF CHILDREN.**

Petrol Containing Alcohol

If you decide to use a petrol containing alcohol (gasohol), be sure it's octane rating is at least as high as that recommended by Honda. There are two types of "gasohol": one containing ethanol, and the other containing methanol. Do not use petrol that contains more than 10% ethanol. Do not use petrol containing methanol (methyl or wood alcohol) that does not also contain cosolvents and corrosion inhibitors for methanol. Never use petrol containing more than 5% methanol, even if it has cosolvents and corrosion inhibitors.

NOTE:

- * Fuel system damage or engine performance problems resulting from the use of fuels that contain alcohol is not covered under the warranty. Honda cannot endorse the use of fuels containing methanol since evidence of their suitability is as yet incomplete.
- * Before buying fuel from an unfamiliar station, try to find out if the fuel contains alcohol. If it does, confirm the type and percentage of alcohol used. If you notice any undesirable operating symptoms while using a petrol that contains alcohol, or one that you think contains alcohol, switch to a petrol that you know does not contain alcohol.

ENGINE OIL

Engine Oil Level Check

Check the engine oil level each day before riding the motorcycle.

The level must be maintained between the upper (2) and lower (3) level marks on the dipstick (1).

1. Start the engine and let it idle for a few minutes. Make sure the red low oil pressure indicator goes off. If the light remains on, stop the engine immediately.
2. Stop the engine and put the motorcycle on its center stand on level ground.
3. After a few minutes, remove the oil filler cap/dipstick, wipe it clean, and reinsert the dipstick without screwing it in. Remove the dipstick. The oil level should be between the upper and lower marks on the dipstick.
4. If required, add the specified oil (see page 63) up to the upper level mark. Do not overfill.

5. Reinstall the oil filler cap/dipstick. Check for oil leaks.

CAUTION:

* **Running the engine with insufficient oil can cause serious engine damage.**

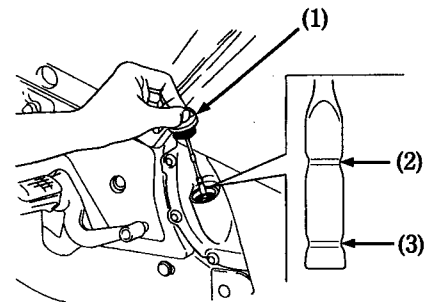

- (1) Filler cap/dipstick (3) Lower level mark
(2) Upper level mark

TUBELESS TYRES

This motorcycle is equipped with tubeless tyres, valves, and wheel rims. Use only tyres marked "TUBELESS" and tubeless valves on rims marked "TUBELESS TYRE APPLICABLE."

Proper air pressure will provide maximum stability, riding comfort and tyre life. Check tyre pressure frequently and adjust if necessary.

NOTE:

- * Tyre pressure should be checked before you ride while the tyres are "cold".
- * Tubeless tyres have some degree of selfsealing ability if they are punctured, and leakage is often very slow. Inspect very closely for punctures, especially if the tyre is not fully inflated.

		Front	Rear
Tyre size		120/70 VR 17-V270	170/60 VR 17-V270
Cold tyre pressures kPa (kg/cm ² , psi)	Driver only	250 (2.50 , 36)	290 (2.90 , 42)
	Driver and one passenger	250 (2.50 , 36)	290 (2.90 , 42)
Tyre brand TUBLESS ONLY BRIDGESTONE DUNLOP		CYROX19E K510A	CYROX16E K510B

Check the tyres for cuts, embedded nails or other sharp objects. Check the rims for dents or deformation. If there is any damage, see your authorized Honda dealer for repair, replacement, and balancing.

▲ WARNING

- * Improper tyre inflation will cause abnormal tread wear and create a safety hazard. Underinflation may result in the tyre slipping on, or coming off of the rim causing tyre deflation that may result in a loss of vehicle control.
- * Operation with excessively worn tyres is hazardous and will adversely affect traction and handling.

Replace tyres before tread depth at the center of the tyre reaches the following limit:

Minimum tread depth	
Front :	1.5 mm (0.06 in)
Rear :	2.0 mm (0.08 in)

Tyre Repair/Replacement:

See your authorized Honda Dealer.

▲ WARNING

- * The use of tyres other than those listed on the tyre information label may adversely affect handling.
- * Do not install tube-type tyres on tubeless rims. The beads may not seat and the tyres could slip on the rims, causing tyre deflation that may result in a loss of vehicle control.
- * Do not install a tube inside a tubeless tyre. Excessive heat build-up may cause the tube to burst resulting in rapid tyre deflation that may result in a loss of vehicle control.

▲ WARNING

- * Proper wheel balance is necessary for safe, stable handling of the motorcycle. Do not remove or change any wheel balance weights. When wheel balancing is required, see your authorized Honda dealer. Wheel balancing is required after tyre repair or replacement.
- * To avoid possible repair failure and tyre deflation that may result in a loss of vehicle control, do not exceed 80 km/h (50 mph) for the first 24 hours, or 130 km/h (80 mph) at any time, after tyre repair.
- * Replace the tyre if the sidewall is punctured or damaged. Sidewall flexing may cause repair failure and tyre deflation that may result in a loss of vehicle control.

CAUTION:

- * Do not try to remove tubeless tyres without special tools and rim protectors. You may damage the rim sealing surface or disfigure the rim.

ESSENTIAL INDIVIDUAL COMPONENTS

IGNITION SWITCH

The ignition switch (1) is below the indicator panel.

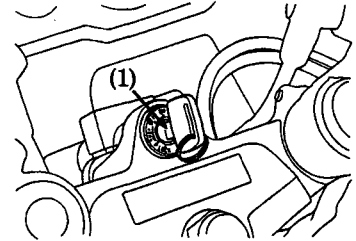

(1) Ignition switch

Key Position	Function	Key Removal
LOCK (steering lock)	Steering is locked. Engine and lights cannot be operated.	Key can be removed
P (parking) (AR type only)	For parking the motorcycle near traffic. The taillight and position light are on, but all other light are off. The engine cannot be started.	Key can be removed
OFF	Engine and lights cannot be operated.	Key can be removed
ON	Engine and lights can be operated.	Key cannot be removed

RIGHT HANDLEBAR CONTROLS < Except AUSTRALIA >

Engine Stop Switch

The engine stop switch (1) is next to the throttle grip. When the switch is in the RUN position, the engine will operate. When the switch is in the OFF position, the engine will not operate. This switch is intended primarily as a safety or emergency switch and should normally remain in the RUN position.

Headlight Switch

The headlight switch (3) has three positions; "H", "P" and "OFF" marked by a dot to the right of "P".

H: Headlight, taillight, position light and meter lights on.

P: Position light, taillight and meter lights on.

OFF (dot): Headlight, taillight, position light and meter lights off.

Starter Button

The starter button (2) is below the engine stop switch (1).

When the starter button is pressed, the starter motor cranks the engine. See page 45 for the starting procedure.

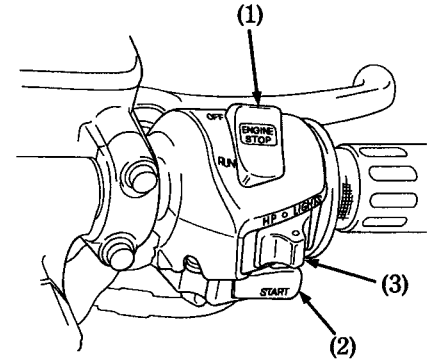

- (1) Engine stop switch
- (2) Starter button
- (3) Headlight switch

RIGHT HANDLEBAR CONTROLS **< For AUSTRALIA only >**

Engine Stop Switch

The engine stop switch (1) is next to the throttle grip. When the switch is in the RUN position, the engine will operate. When the switch is in the OFF position, the engine will not operate. This switch is intended primarily as a safety or emergency switch and should normally remain in the RUN position.

Starter Button

The starter button (2) is below the engine stop switch (1). When the starter button is pressed, the starter motor cranks the engine. See page 45 for the starting procedure.

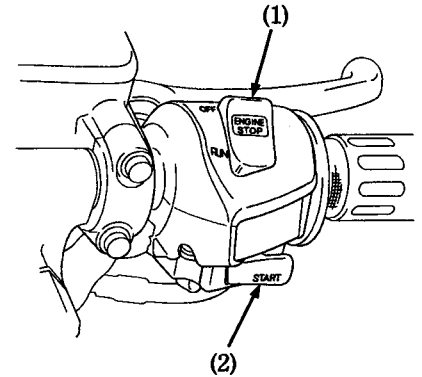

- (1) Engine stop switch
- (2) Starter button

LEFT HANDLEBAR CONTROLS

Headlight Dimmer Switch (1)

Push the dimmer switch to “HI” to select high beam or to “LO” to select low beam.

< Except AUSTRALIA >

Passing Light Control Switch (2)

When this switch is pressed, the headlight flashes on to signal approaching cars or when passing.

Turn Signal Switch (3)

Move to L to signal a left turn, R to signal a right turn. Remember to return the switch to the center (off) after completing your turn or lane change.

Horn Button (4)

Press the button to sound the horn.

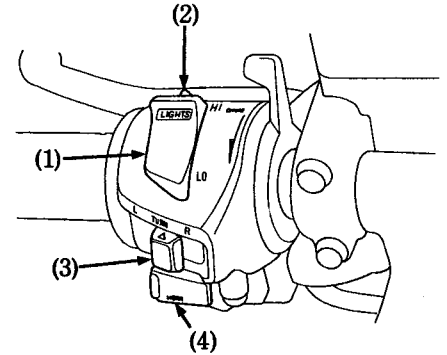

- (1) Headlight dimmer switch
- (2) Passing light control switch
- (3) Turn signal switch
- (4) Horn button

FEATURES (Not required for operation)

STEERING LOCK

To lock the steering, turn the handlebars all the way to the left or right, turn the key (1) to P or LOCK while pushing in. Remove the key.

▲ WARNING

*** Do not turn the key to P or LOCK while riding the motorcycle; loss of vehicle control will result.**

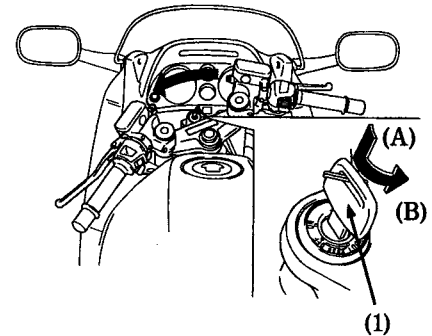

(1) Ignition key

(A) Push in

(B) Turn to P or
LOCK

HELMET HOLDER

The helmet holder (1) is on the left side below the seat. Insert the ignition key (2) and turn it counterclockwise to unlock. Hang your helmet on the holder pin (3) and push it in to lock. Remove the key.

▲ WARNING

- * **The helmet holder is designed for helmet security while parked. Do not ride with a helmet attached to the holder; the helmet may interfere with safe operation and result in loss of control.**
- * **As the helmet holder and seat lock are combined, confirm that locking is properly completed by lifting up the seat after using helmet holder.**

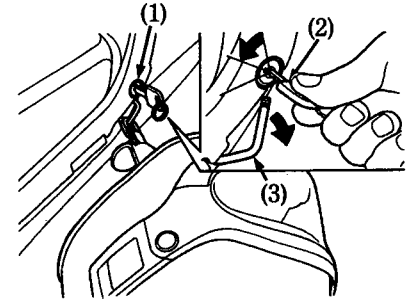

(1) Helmet holder
(2) Ignition key

(3) Holder pin

SEAT

To remove the seat (1), insert the ignition key (2) into the helmet holder (3) turn it counterclockwise.

Remove the seat by pulling up and rearward.

To install the seat, insert the prong A (4) into the recess A (5) and set the prong B (6) against the fuel tank (7). Then set the hook (8) against the recess B (9). Push the rear of the seat down to lock the seat.

CAUTION:

* Be sure the seat is locked securely in position after installation.

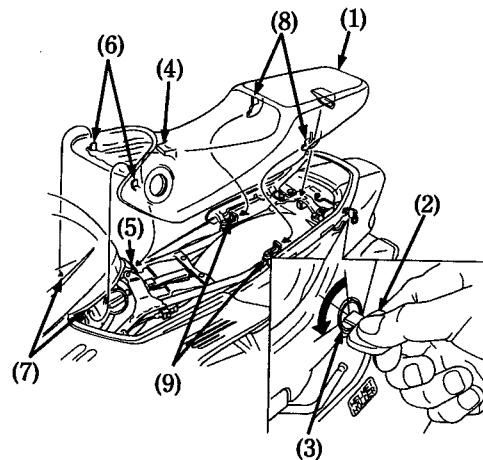

- | | |
|------------------|-------------------|
| (1) Seat | (3) Helmet holder |
| (2) Ignition key | (6) Prong B |
| (4) Prong A | (5) Recess A |
| (7) Fuel tank | (8) Hook |
| | (9) Recess B |

DOCUMENT COMPARTMENT

The document compartment (1) is underneath the rear cowl.

This owner's manual and other documents should be stored in the compartment.

When washing your motorcycle, be careful not to flood this area with water.

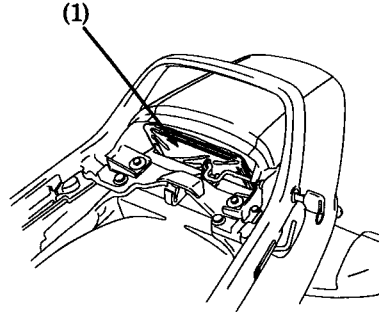

(1) Document compartment

CORD HOOK

This motorcycle is equipped with the retractable luggage cord hooks (1).

CAUTION:

* **Never use this cord hook to tow or lift the motorcycle.**

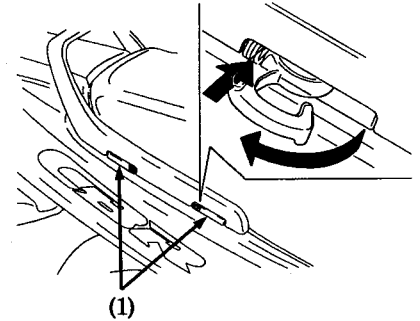

(1) Cord hooks

SIDE COVER

The side cover (1) must be removed for main fuse, air cleaner and rear brake fluid maintenance. To remove the side cover, turn the clip (2) 90° counterclockwise so that the groove in the clip is level, pull out the prong (3) and then gently pull the side cover forward to release the tabs (4). Remove the side cover.

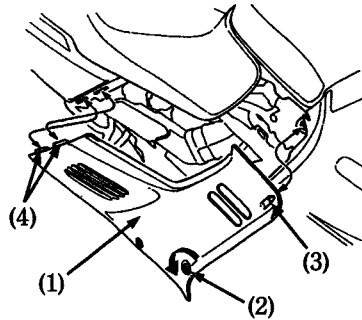

- | | |
|----------------|----------|
| (1) Side cover | (3) Clip |
| (2) Prong | (4) Tabs |

LOWER FAIRING

Removal:

1. Remove the side cover (see page 40).
2. Remove the two crips A (1) and the lid (2).
3. Remove the clips B (3).
4. Remove the three trim clips (4).
5. Remove the two crips C (5).

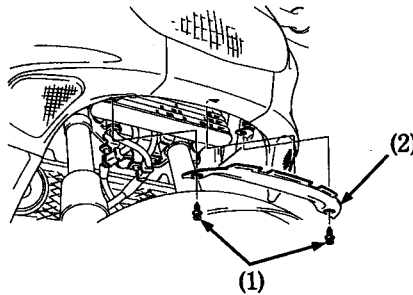

(1) Clip A

(2) Lid

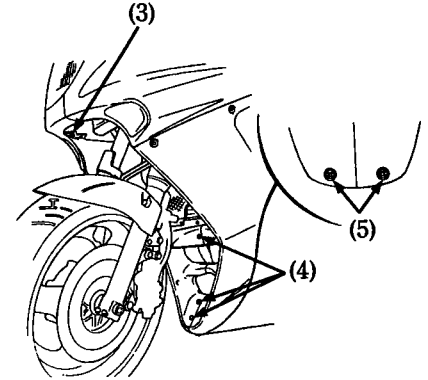

(3) Clip B
(5) Clip C

(4) Trim clip

6. Remove the two bolts (6).
7. Remove the lower fairing cover (7) and the screw (8).
8. Remove the short mount screw(9).
9. Remove the clip (10) from the plate (11).
10. Remove the three long mount screws (12) while holding the lower fairing.
11. Remove the lower fairing.

Installation:

1. Installation can be done in the reverse order of removal.

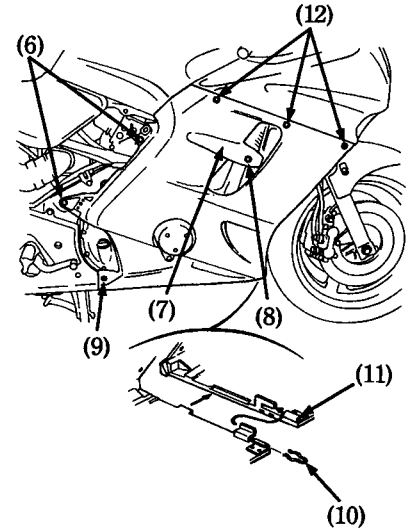

- (6) Bolt
(7) Lower fairingcover (8) Screw
(9) Short mount screw (10) Clip
(11) Plate (12) Long mount screw

OPERATION

PRE-RIDE INSPECTION

▲ WARNING

*** If the Pre-ride Inspection is not performed, severe personal injury or vehicle damage may result.**

Inspect your motorcycle every day before you ride it. The items listed here will only take a few minutes to inspect, and in the long run they can save time, expense, and possibly your life.

1. Engine oil level—add engine oil if required (page 28). Check for leaks .
2. Fuel level—fill fuel tank when necessary (page 26). Check for leaks .
3. Coolant level—add coolant if required. Check for leaks (pages 22 – 23) .
4. Front and rear brakes—check operation; make sure there is no brake fluid leakage (pages 17 – 20).

5. Tyres—check condition and pressure (page 29–31).
6. Drive chain—check condition and slack (page 72). Adjust and lubricate if necessary.
7. Throttle—check for smooth opening and full closing in all steering positions
8. Lights and horn—check that headlight, tail/brake light, turn signals, indicators and horn function properly.
9. Engine stop switch—check for proper function (page 33).
10. Side stand ignition cut-off system—check for proper function (page 78).
11. Battery electrolyte—check the level and add if necessary (page 90).

Correct any discrepancy before you ride. Contact your authorized Honda dealer for assistance if you cannot correct the problem.

STARTING THE ENGINE

This motorcycle is equipped with a side stand ignition cut-off system. The engine cannot be started if the side stand is down, unless the transmission is in neutral. If the side stand is up, the engine can be started in neutral or in gear with the clutch lever pulled in. After starting with the side stand down, the engine will shut off if the transmission is put in gear before raising the side stand.

▲ WARNING

- * **Never run the engine in an enclosed area. The exhaust contains poisonous carbon monoxide gas that can cause loss of consciousness and lead to death.**

NOTE:

- * Do not use the electric starter for more than 5 seconds at a time. Release the starter button for approximately 10 seconds before pressing it again.

NOTE:

- * The electric starter will work when the transmission is in gear with the clutch disengaged.

Preparation

Before starting, insert the key, turn the ignition switch ON and confirm the following:

- The transmission is in NEUTRAL (neutral indicator light ON).
- The engine stop switch is at RUN.
- The red low oil pressure indicator is ON.
- The fuel cock is ON.

Starting Procedure

1. Pull the choke lever (1) back all the way to Fully ON (A), if the engine is cold.
2. Press the starter button, leaving the throttle closed.
3. Warm up the engine by opening and closing the throttle until it runs smoothly, with the choke lever Fully OFF.

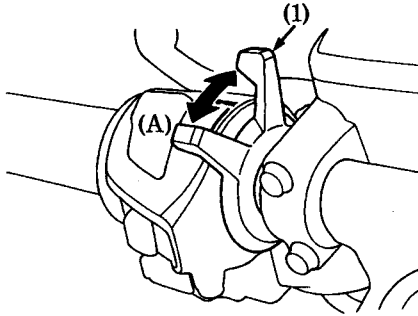

(1) Chock lever

CAUTION:

- * The red low oil pressure indicator should go off a few seconds after the engine starts. If the light stays on, stop the engine immediately and check engine oil level. Operating the engine with insufficient oil pressure can cause serious engine damage.

Flooded Engine

If the engine fails to start after repeated attempts, it may be flooded with excess fuel. To clear a flooded engine, turn the engine stop switch to OFF and push the choke lever forward to Fully OFF (B). Open the throttle fully and crank the engine for 5 seconds. Wait 10 seconds, then turn the engine stop switch to RUN and follow the Starting Procedure (page 45).

RUNNING-IN

During initial running-in newly machined surfaces will be in contact with each other and these surfaces will wear in quickly. Running-in maintenance at 1,000km (600 miles) is designed to compensate for this initial minor wear. Timely performance of the running-in maintenance will ensure optimum service life and performance from the engine.

The general rules as follows:

1. Never labour the engine with full throttle at low engine speeds. This rule is applicable not only during running-in but at all times.
2. Maximum continuous engine speed during the first 1,000 km (600 miles) must not exceed 5,000 min^{-1} (rpm).
3. Increase the maximum continuous engine speed by 2,000 min^{-1} (rpm) between odometer readings of 1,000 km (600 miles) and 1,600 km (1,000 miles). Drive briskly, vary speeds frequently and use full throttle for short bursts only. Do not exceed 7,000 min^{-1} (rpm).

4. Upon reaching an odometer reading of 1,600 km (1,000 miles), you can subject the motorcycle to full throttle operation. However, do not exceed 10,500 rpm at any time (tachometer red zone limit).

CAUTION:

*** Running the engine beyond recommended maximum engine speed (tachometer red zone) can damage the engine.**

RIDING

▲ WARNING

- * **Review Motorcycle Safety (pages 1 – 5) before you ride.**

NOTE:

- * Make sure you understand the function of the side stand mechanism. (See **MAINTENANCE SCHEDULE** on page 54 and explanation for **SIDE STAND** on page 78)
1. After the engine has been warmed up, the motorcycle is ready for riding.
 2. While the engine is idling, pull in the clutch lever and depress the gearshift pedal to shift into 1st (low) gear.
 3. Slowly release the clutch lever and at the same time gradually increase engine speed by opening the throttle. Coordination of the throttle and clutch lever will assure a smooth positive start.

4. When the motorcycle attains a moderate speed, close the throttle, pull in the clutch lever and shift to 2nd gear by raising the gearshift pedal.

This sequence is repeated to progressively shift to 3rd, 4th, 5th and 6th(top) gear.

5. Coordinate the throttle and brakes for smooth deceleration.
6. Both front and rear brakes should be used at the same time and should not be applied strongly enough to lock the wheel, or braking effectiveness will be reduced and control of the motorcycle be difficult.

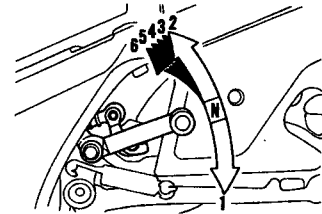

BRAKING

This motorcycle is equipped with a Dual Combined Brake System. Operating the front brake lever applies the front brake and a portion of the rear brake. Operating the rear brake pedal applies the rear brake and a portion of the front brake. For full braking effectiveness, use both the lever and pedal simultaneously, as you would with a conventional motorcycle braking system.

As with a conventional motorcycle braking system, excessively hard application of the brake controls may cause wheel lock, reducing control of the motorcycle.

For normal braking, apply both the brake lever and brake pedal while downshifting to match your road speed. For maximum braking, close the throttle and firmly apply the lever and pedal. Pull in the clutch before coming to a complete stop to prevent stalling the engine.

Important Safety Reminders:

- * **When possible, reduce speed or brake before entering a turn; closing the throttle or braking in mid-turn may cause wheel slip. Wheel slip will reduce control of the motorcycle.**
- * **When riding in wet or rainy conditions, or on loose surfaces, the ability to maneuver and stop will be reduced. All of your actions should be smooth under these conditions. Rapid acceleration, braking or turning may cause loss of control. For your safety, exercise extreme caution when braking, accelerating or turning.**

- * When descending a long, steep grade, use engine compression braking by downshifting, with intermittent use of both brakes. Continuous brake application can overheat the brakes and reduce their effectiveness.**
- * Riding with your foot resting on the brake pedal or your hands on the brake lever may actuate the brakelight, giving a false indication to other drivers. It may also overheat the brake, reducing effectiveness.**

PARKING

1. After stopping the motorcycle, shift the transmission into neutral, turn the fuel cock OFF, turn the handlebar fully to the left, turn the ignition switch OFF and remove the key.
2. Use the side or center stand to support the motorcycle while parked.

CAUTION:

- * **Park the motorcycle on firm, level ground to prevent it from falling over.**
 - * **If you must park on a slight incline, aim the front of the motorcycle uphill to reduce the possibility of rolling off the side stand or overturning.**
3. Lock the steering to help prevent theft (page 36).

〈 AR type only 〉

NOTE:

- * When stopping for a short time near traffic at night, the ignition switch may be turned to P and the key removed. This will turn on the taillight to make the motorcycle more visible to traffic. The battery will discharge if the ignition switch is left at P for too long a time.

ANTI-THEFT TIPS

1. Always lock the steering and never leave the key in the ignition switch. This sounds simple but people do forget.
2. Be sure the registration information for your motorcycle is accurate and current.
3. Park your motorcycle in a locked garage whenever possible.
4. Use an additional anti-theft device of good quality.
5. Put your name, address, and phone number in this Owner's Manual and keep it on your motorcycles at all times. Many times stolen motorcycles are identified by information in the Owner's Manuals that are still with them.

NAME: _____

ADDRESS: _____

PHONE NO: _____

MAINTENANCE

- When service is required, remember that your authorized Honda dealer knows your motorcycle best and is fully equipped to maintain and repair it. The scheduled maintenance may also be performed by a qualified service facility that normally does this kind of work; or you may perform most of the work yourself if you are mechanically qualified and have the proper tools and service data.
- These instructions are based on the assumption that the motorcycle will be used exclusively for its designed purpose. Sustained high speed operation, or operation in unusually wet or dusty conditions, will require more frequent service than specified in the **MAINTENANCE SCHEDULE**. Consult your authorized Honda dealer for recommendations applicable to your individual needs and use.

MAINTENANCE SCHEDULE

The following items require some mechanical knowledge. Certain items (particularly those marked * and * *) may require more technical information and tools. Consult your authorized Honda Dealer.

Perform the Pre-ride Inspection (page 43) at each scheduled maintenance period.

I: INSPECT AND CLEAN, ADJUST, LUBRICATE OR REPLACE IF NECESSARY

C: CLEAN R: REPLACE A: ADJUST L: LUBRICATE

ITEM	FREQUENCY	WHICHEVER →	ODOMETER READING [NOTE(1)]								REFER TO PAGE	
			COMES FIRST ↓	x1,000km	1	6	12	18	24	30		36
				x1,000mi	0.6	4	8	12	16	20		24
			NOTE	MONTH	6	12	18	24	30	36		
* FUEL LINE					I		I		I	—		
* THROTTLE OPERATION					I		I		I	70		
* CARBURETOR CHOKE					I		I		I	—		
AIR CLEANER	(NOTE 2)					R			R	60		
CRANKCASE BREATHER	(NOTE 3)			C	C	C	C	C	C	62		
SPARK PLUG				I	R	I	R	I	R	67-69		
* VALVE CLEARANCE				I		I		I		—		
ENGINE OIL				R		R		R		63-66		
ENGINE OIL FILTER				R		R		R		64-66		
* CARBURETOR SYNCHRONIZATION						I		I		—		
* CARBURETOR IDLE SPEED				I	I	I	I	I	I	71		
RADIATOR COOLANT	(NOTE 4)					I		I	R	22-23		
* COOLING SYSTEM						I		I		—		
* SECONDARY AIR SUPPLY SYSTEM	(NOTE 5)					I		I		—		

ITEM	FREQUENCY	WHICHEVER →		ODOMETER READING [NOTE(1)]								REFER TO PAGE
		COMES FIRST ↓	x1,000km	1	6	12	18	24	30	36		
			x1,000mi	0.6	4	8	12	16	20	24		
		NOTE	MONTH	6	12	18	24	30	36			
	DRIVE CHAIN			I, L	EVERY	1,000 km (600 mi)						72-76
	DRIVE CHAIN SLIDER				I		I		I			77
	BATTERY				I	I	I	I	I			90-92
	BRAKE FLUID	(NOTE 4)			I	I	R	I	I	R		17-20
	BRAKE PAD WEAR				I	I	I	I	I			87
	BRAKE SYSTEM			I		I		I	I			17-20,89
*	BRAKE LIGHT SWITCH					I		I		I		95
*	HEADLIGHT AIM					I		I		I		-
	CLUTCH SYSTEM					I		I		I		21
	CLUTCH FLUID	(NOTE 4)			I	I	R	I	I	R		21
	SIDE STAND					I		I		I		78
*	SUSPENSION					I		I		I		77
*	NUTS, BOLTS, FASTENERS			I		I		I		I		-
**	WHEELS/TYRES					I		I		I		-
**	STEERING HEAD BEARINGS			I		I		I		I		-

* SHOULD BE SERVICED BY YOUR AUTHORIZED HONDA DEALER, UNLESS THE OWNER HAS PROPER TOOLS AND SERVICE DATA AND IS MECHANICALLY QUALIFIED. REFER TO THE OFFICIAL HONDA SHOP MANUAL.

** IN THE INTEREST OF SAFETY, WE RECOMMEND THESE ITEMS BE SERVICED ONLY BY YOUR AUTHORIZED HONDA DEALER.

- NOTES: 1. At higher odometer readings, repeat at the frequency interval established here.
2. Service more frequently when riding in unusually wet or dusty areas.
3. Service more frequently when riding in rain or at full throttle.
4. Replace every 2 years, or at indicated odometer interval, whichever comes first. Replacement requires mechanical skill.
5. Switzerland and Austria type only.

TOOL KIT

The tool kit (1) is in the tool box under the seat.

Some roadside repairs, minor adjustments and parts replacement can be performed with the tools contained in the kit.

- Spark plug wrench
- 8 mm box wrench
- 10x12 mm box end wrench
- 22 mm box end wrench
- 27 mm box end wrench
- 8 mm open end wrench
- 10 x 12 mm open end wrench
- 14 x 17 mm open end wrench
- Pliers
- 5 mm hex wrench
- 6 mm hex wrench
- No.2 screwdriver
- No.2 Phillips screwdriver
- Screwdriver grip
- Tool bag
- Breaker bar

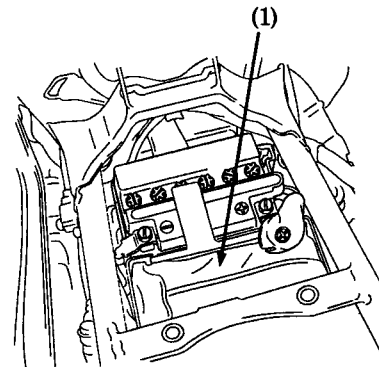

(1) Tool kit

SERIAL NUMBERS

The frame and engine serial numbers are required when registering your motorcycle. They may also be required by your dealer when ordering replacement parts. Record the numbers here for your reference.

FRAME NO. _____

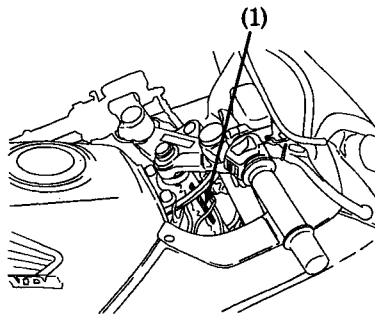

(1) Frame number

The frame number (1) is stamped on the right side of the steering head.

The engine number (2) is stamped on top of the crankcase.

ENGINE NO. _____

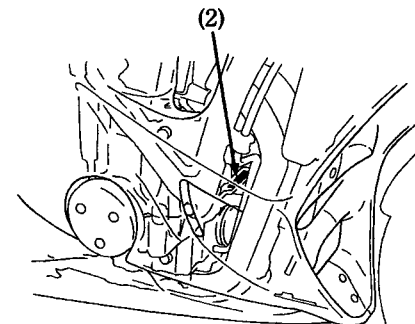

(2) Engine number

COLOUR LABEL

The colour label (1) is attached to the frame below the seat (See page 38).

It is helpful when ordering replacement parts. Record the colour and code here for your reference.

COLOUR _____

CODE _____

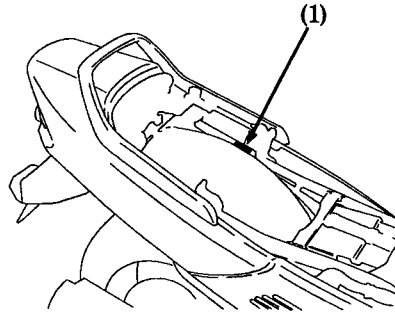

(1) Colour label

MAINTENANCE PRECAUTIONS

▲ WARNING

- * **If your motorcycle is overturned or involved in a collision, inspect control levers, cables, brake hoses, calipers, accessories, and other vital parts for damage. Do not ride the motorcycle if damage impairs safe operation. Have your authorized Honda dealer inspect the major components, including frame, suspension and steering parts, for misalignment and damage that you may not be able to detect.**
- * **Stop the engine and support the motorcycle securely on a firm, level surface before performing any maintenance.**
- * **Use new, genuine Honda parts or their equivalent for maintenance and repair. Parts which are not of equivalent quality may impair the safety of your motorcycle.**

AIR CLEANER

(Refer to the maintenance precautions on page 59).

The air cleaner should be serviced at regular intervals (page 54). Service more frequently when riding in unusually wet or dusty areas.

1. Remove the seat (page38).
2. Remove the right side cover (page40).
3. Remove the duct (1) by removing bolt (2).
4. Remove the air cleaner case cover (3) by removing screws (4).

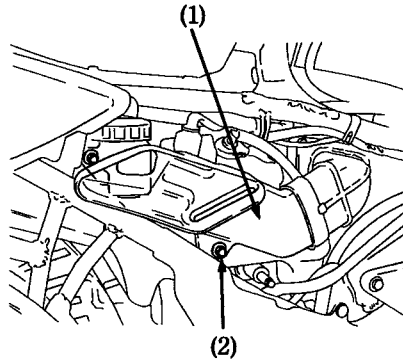

(1) Duct

(2) Bolt

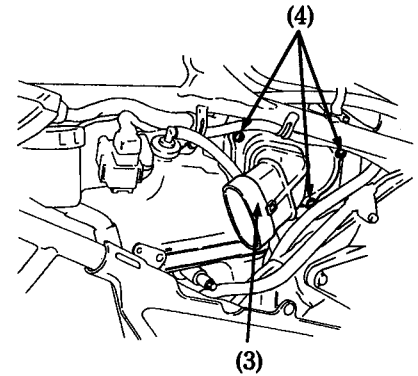

(3) Air cleaner case cover (4) Screws

5. Pull out the retainer (5).
6. Pull out the air cleaner element (6).
7. Discard the air cleaner element.
8. Install a new air cleaner element.

Use the Honda genuine air filter or an equivalent filter specified for your model. Using the wrong Honda filter or a non-Honda filter which is not of equivalent quality may cause premature engine wear or performance problems.

9. Install the removed parts in the reverse order of disassembly.

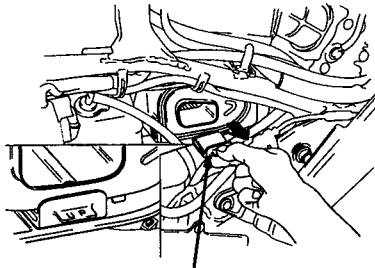

(5) Retainer

(5)

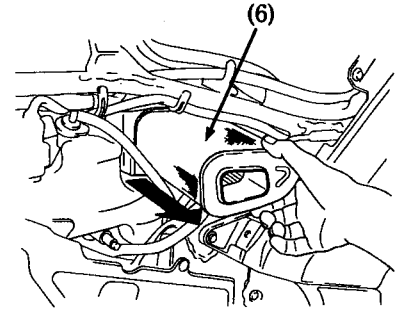

(6) Air cleaner element

CRANKCASE BREATHER

(Refer to the maintenance precautions on page 59).

1. Remove the drain plug (1) from the tube and drain deposits into a suitable container.

2. Reinstall the drain plug.

NOTE:

* Service more frequently when riding in rain, at full throttle, or after the motorcycle is washed or overturned. Service if the deposit level can be seen in the transparent section of the drain tube.

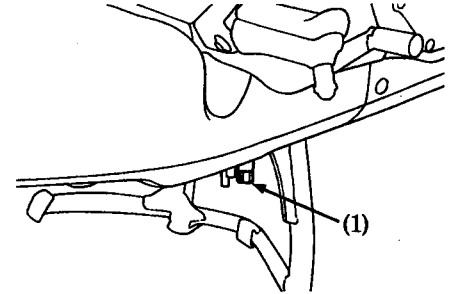

(1) Drain plug

ENGINE OIL

(Refer to the maintenance precautions on page 59).

Engine Oil

Good engine oil has many desirable qualities. Use only high detergent, quality motor oil certified on the container to meet or exceed requirements for service SE, SF or SG.

Viscosity:

Viscosity grade of engine oil should be based on average atmospheric temperature in your riding area. The following provides a guide to the selection of the proper grade or viscosity of oil to be used at various atmospheric temperatures.

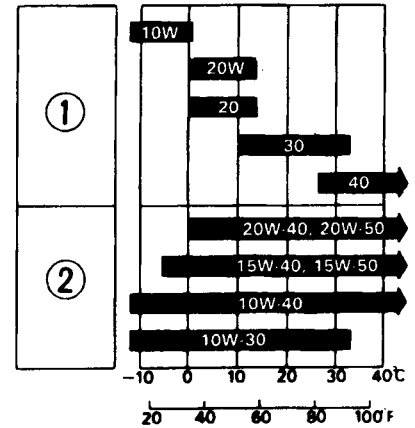

(1) Single grade

(2) Multigrade

Engine Oil and Filter

Engine oil quality is the chief factor affecting engine service life. Change the engine oil as specified in the maintenance schedule (page 54).

Changing the oil filter requires a special oil filter tool and a torque wrench. If you do not have these tools and the necessary skill, we recommend that you have your authorized Honda dealer perform this service. If a torque wrench is not used for this installation, see your authorized Honda dealer as soon as possible to verify proper assembly.

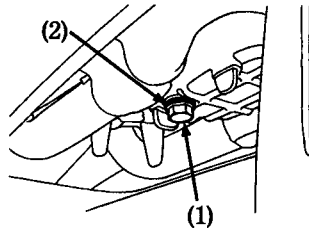

(1) Oil drain plug

(2) Sealing washer

NOTE:

- * Change the engine oil with the engine at normal operating temperature and the motorcycle on its side stand to assure complete and rapid draining.

CAUTION:

- * **To prevent oil leaks and filter damage, never support the engine on the oil filter.**

1. Remove the lower fairing (page 41).
2. To drain the oil, remove the oil filler cap and crankcase drain plug (1) and sealing washer (2).

A WARNING

- * **A warmed-up engine and the oil in it are hot; be careful not to burn yourself.**

3. Remove the oil filter (3) with a filter wrench and let the remaining oil drain out.

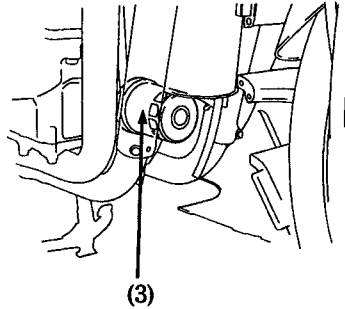

(3) Oil filter

4. Apply a thin coat of engine oil to the new oil filter rubber seal (4).
5. Using a special tool and a torque wrench, install the new oil filter and tighten to a torque of:
10 N·m (1.0 kg·m , 7 lb-ft)

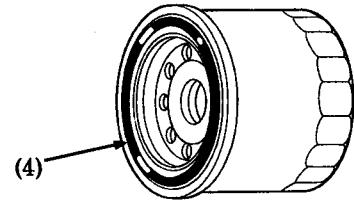

(4) Oil filter rubber seal

6. Use only the Honda genuine oil filter or a filter of equivalent quality specified for your model. Using the wrong Honda filter or a non-Honda filter which is not of equivalent quality may cause engine damage.
7. Check that the sealing washer on the drain plug is in good condition and install the plug. Replace the sealing washer every other time the oil is changed, or each time if necessary.
Oil Drain Plug Torque:
30 N·m (3.0 kg·m, 22 lb-ft)
8. Fill the crankcase with the recommended grade oil; approximately:
3.8 ℓ (4.0 US qt, 3.3 Imp qt)
9. Install the oil filler cap.
10. Start the engine and let it idle for 2–3 minutes.
11. Several minutes after stopping the engine, check that the oil level is at the upper level mark on the dipstick with the motorcycle upright on firm, level ground. Make sure there are no oil leaks.

NOTE:

- * When running in very dusty conditions, oil changes should be performed more frequently than specified in the maintenance schedule.
- * Please dispose of used engine oil in a manner that is compatible with the environment. We suggest you take it in a sealed container to your local recycling center or service station for reclamation. Do not throw it in the rubbish or pour it on the ground.

CAUTION:

- * **Used engine oil may cause skin cancer if repeatedly left in contact with the skin for prolonged periods. Although this is unlikely unless you handle used oil on a daily basis, it is still advisable to thoroughly wash your hands with soap and water as soon as possible after handling used oil.**

SPARK PLUGS

(Refer to the maintenance precautions on page 59).

Recommended plugs:

Standard:

DPR9EA-9 (NGK) or

X27EPR-U9 (NIPPONDENSO)

1. Remove the seat (see page 38).
2. Remove the fuel tank front mount bolts (1) and washer (2).

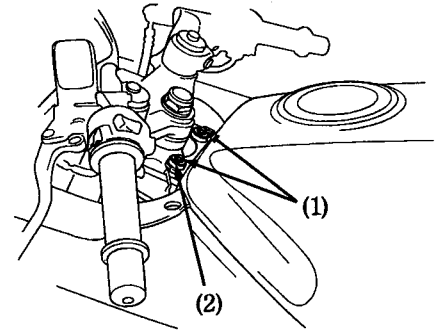

(1) Mount bolts

(2) Washer

3. Raise the fuel tank until the prop stay (2) is locked.
4. Clean any dirt from around the spark plug base. Remove the spark plug using the plug wrench (3) furnished in the tool kit.

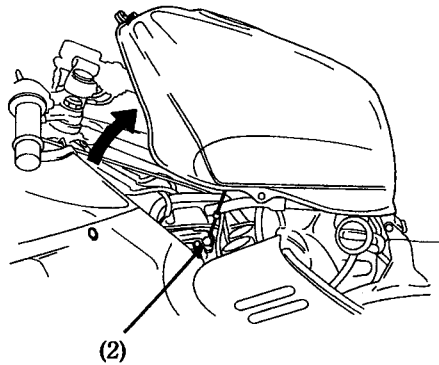

(2) Prop stay

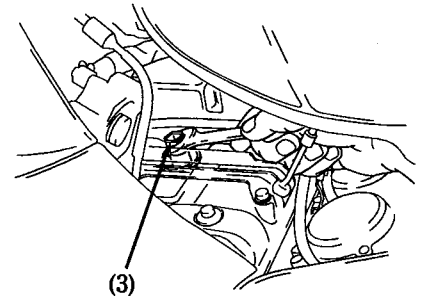

(3) Plug wrench

5. Inspect the electrodes and center porcelain for deposits, erosion or carbon fouling. If the erosion or deposit is heavy, replace the plug. Clean a carbon or wet-fouled plug with a plug cleaner, otherwise use a wire brush.
6. Check the new spark plug gap (4) using a wire-type feeler gauge. If adjustment is necessary, bend the side electrode (5) carefully.
The gap should be:
0.80—0.90 mm (0.031—0.035 in)
Make sure the plug washer is in good condition.
7. With the plug washer attached, thread the spark plug in by hand to prevent cross-threading.
8. Tighten the spark plug 1/2 turn with a spark plug wrench to compress the washer.
9. Reinstall the spark plug caps.

CAUTION:

- * The spark plug must be securely tightened. An improperly tightened plug can become very hot and possibly damage the engine.
- * Never use a spark plug with an improper heat range. Severe engine damage could result.

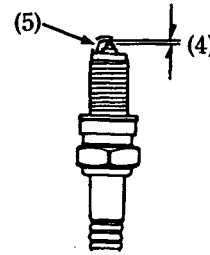

(4) Spark plug gap

(5) Side electrode

THROTTLE OPERATION

(Refer to the maintenance precautions on page 59).

1. Check for smooth rotation of the throttle grip from the fully open to the fully closed position at both full steering positions.
2. Measure the throttle grip free play at the throttle grip flange.
The standard free play should be approx:
2—6 mm (0.08—0.24 in)
To adjust the play, loosen the lock nut (1) and turn the adjuster (2).

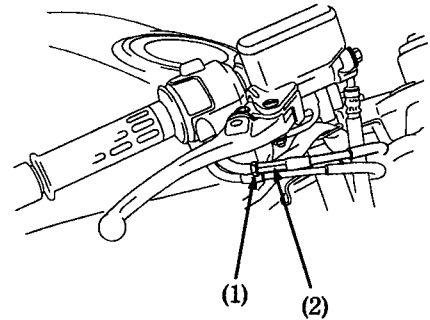

(1) Lock nut

(2) Adjuster

IDLE SPEED

(Refer to the maintenance precautions on page 59).

The idle speed adjustment procedure given here should only be used when changes in altitude affect normal idle speed as set by your dealer. See your authorized Honda dealer for regularly scheduled carburetor adjustments, including individual carburetor adjustment and synchronization.

NOTE:

* The engine must be at normal operating temperature for accurate idle speed adjustment. Ten minutes of stop-and-go riding is sufficient.

1. Warm up the engine, and shift to neutral, and place the motorcycle on its centerstand.
2. The throttle stop screw (1) is behind the seal rubber in the left side cover. Push in the rubber.
3. Adjust idle speed with the throttle stop screw (1).

Idle Speed : (In neutral)

1,000±100 rpm (Except SW, AR)

1,050±50 rpm (SW only)

1,050±100 rpm (AR only)

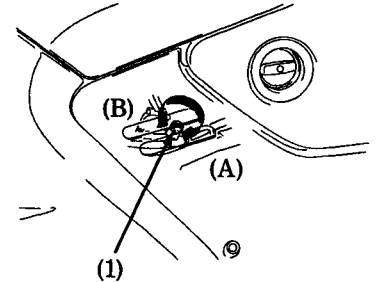

(1) Throttle stop screw

(A) Increase

(B) Decrease

DRIVE CHAIN

(Refer to the maintenance precautions on page 59).

The service life of the drive chain is dependent upon proper lubrication and adjustment. Poor maintenance can cause premature wear or damage to the drive chain and sprockets.

The drive chain should be checked and lubricated as part of the Pre-ride Inspection (page 43). Under severe usage, or when the motorcycle is ridden in unusually dusty or muddy areas, more frequent maintenance will be necessary.

Inspection :

1. Turn the engine off, place the motorcycle on its center stand, and shift the transmission into neutral.
2. Check slack in the lower drive chain run midway between the sprockets.
Drive chain slack should be adjusted to allow the following vertical movement by hand:
15—25 mm (5/8 — 1 in)

3. Rotate the rear wheel. Stop. Check the drive chain slack. Repeat this procedure several times. Drive chain slack should remain constant. If the chain is slack only in certain sections, some links are kinked and binding. Binding and kinking can frequently be eliminated by lubrication.

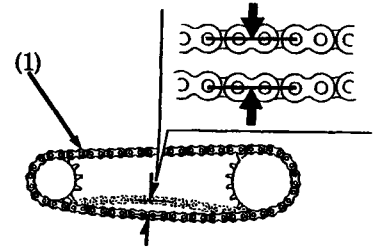

(1) Drive chain

4. Rotate the rear wheel slowly and inspect the drive chain and sprockets for any of the following conditions:

DRIVE CHAIN

- *Damaged Rollers
- *Loose Pins
- *Dry or Rusted Links
- *Kinked or Binding Links
- *Excessive Wear
- *Improper Adjustment
- *Missing O-rings

SPROCKETS

- *Excessively Worn Teeth
- *Broken or Damaged Teeth

A drive chain with damaged rollers, loose pins, or missing O-rings must be replaced. A chain which appears dry, or shows signs of rust, requires supplementary lubrication. Kinked or binding links should be thoroughly lubricated and worked free. If links cannot be freed, the chain must be replaced.

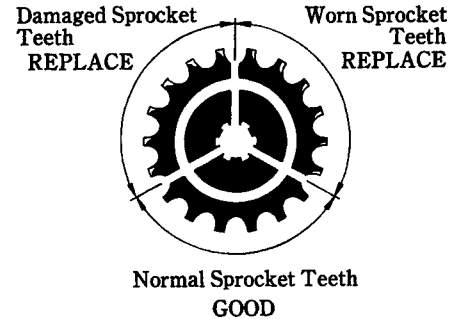

Adjustment:

Drive chain slack should be checked and adjusted, if necessary, every 1,000 km (600 miles). When operated at sustained high speeds or under conditions of frequent rapid acceleration, the chain may require more frequent adjustment.

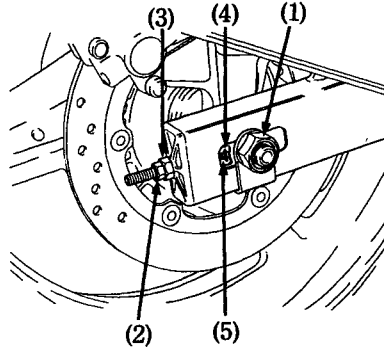

- | | |
|----------------------------------|------------------|
| (1) Axle nut | (4) Index mark |
| (2) Lock nut | (5) Rear edge of |
| (3) Drive chain
adjusting nut | adjusting slot |

If the drive chain requires adjustment, the procedure is as follows:

1. Place the motorcycle on its center stand with the transmission in neutral and the ignition switch off.
2. Loosen the axle nut (1).
3. Loosen the lock nuts (2) on both adjusting nuts (3).
4. Turn both adjusting nuts (3) an equal number of turns until the correct drive chain slack is obtained. Turn the adjusting nuts clockwise to tighten the chain, or counterclockwise to provide more slack. Adjust the chain slack at a point midway between the drive sprocket and the rear wheel sprocket. Rotate the rear wheel and recheck slack at other sections of the chain.

Chain slack should be:

15–25 mm (5/8–1 in)

5. Check rear axle alignment by making sure the chain adjuster index marks (4) align with the rear edge (5) of the adjusting slots.
Both left and right marks should correspond. If the axle is misaligned, turn the left or right adjusting nut until the marks correspond on the rear edge of the adjusting slots and recheck chain slack.
6. Tighten the axle nut to :
93 N·m (9.3 kg-m , 67 lb-ft)
7. Tighten the adjusting nuts lightly, then tighten the lock nuts by holding the adjusting nuts with a spanner.

Wear inspection:

Check the chain wear label when adjusting the chain. If the red zone (6) on the label aligns with the arrow mark (7) on the chain adjuster plates after the chain has been adjusted to the proper slack, the chain is excessively worn and must be replaced. The proper slack is:

15—25 mm (5/8—1 in)

CAUTION:

- * **Damage to the bottom part of the frame may be caused by excessive drive chain slack of more than:
40 mm (1.6 in)**

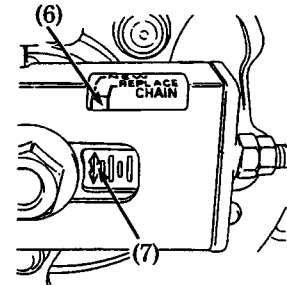

(6) Red zone

(7) Arrow mark

Lubrication and cleaning:

Lubricate every 1,000 km (600 miles) or sooner if chain appears dry.

The O-rings in this chain can be damaged by steam cleaning, high pressure washers, and certain solvents. Clean the chain with high flash-point solvent, such as paraffin. Wipe dry and lubricate only with SAE 80 or 90 gear oil. Commercial chain lubricants may contain solvents which could damage the rubber O-rings.

Replacement Chain:

RK50LFO or D.I.D.50ZV

CAUTION:

* **The drive chain on this motorcycle is equipped with small O-rings between the link plates. These O-rings retain grease inside the chain to improve its service life. However, special precautions must be taken when adjusting, lubricating, washing, and replacing the chain.**

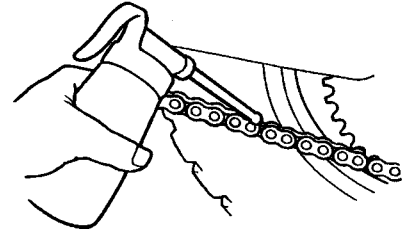

DRIVE CHAIN SLIDER

(Refer to the maintenance precautions on page 59).

Check the chain slider (1) for wear. The chain slider must be replaced if it is worn to the wear limit line (2). For replacement, see your authorized Honda dealer.

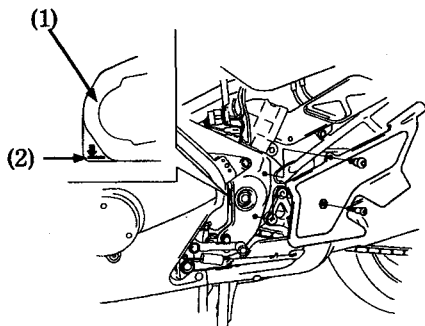

(1) Chain slider

(2) Wear limit line

FRONT AND REAR SUSPENSION INSPECTION

(Refer to the maintenance precautions on page 59).

1. Check the fork assembly by locking the front brake and pumping the fork up and down vigorously. Suspension action should be smooth and there must be no oil leakage.
2. Swingarm bearings should be checked by pushing hard against the side of the rear wheel while the motorcycle is on the center stand. Free play indicates worn bearings.
3. Carefully inspect all front and rear suspension fasteners for tightness.

SIDE STAND

(Refer to the maintenance precautions on page 59).

Perform the following maintenance in accordance with the maintenance schedule.

Functional Check :

- Check the spring (1) for damage or loss of tension and the side stand assembly for freedom of movement.
- Check the side stand ignition cut-off system:
 1. Sit astride the motorcycle; put the side stand up and the transmission in neutral.
 2. Start the engine and with the clutch lever pulled in, shift the transmission into gear.
 3. Lower the side stand. The engine should stop as you put the side stand down.

If the side stand system does not operate as described, see your authorized Honda dealer for service.

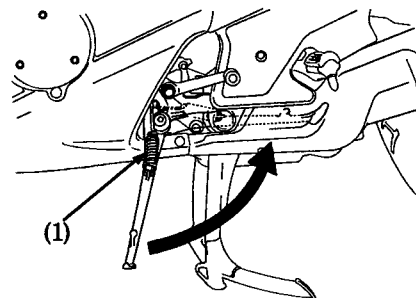

(1) Spring

WHEEL REMOVAL

(Refer to the maintenance precautions on page 59).

Front Wheel Removal

1. Raise the front wheel off the ground by placing a support block under the engine.
2. Remove the right caliper assembly (1) from the fork leg by removing the fixing bolts (2).

CAUTION:

* To avoid damage to the brake hose, support the caliper assembly so that it doesn't hang from the hose. Do not twist the brake hose.

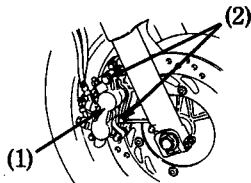

(1) Right caliper assembly (2) Fixing bolts

3. Cover the front wheel with a protective tape or equivalent.

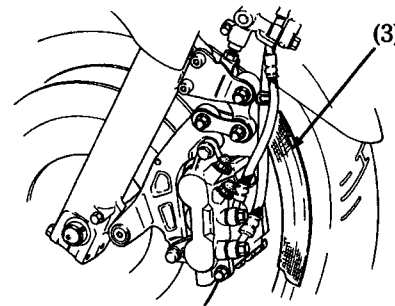

(3) Protective tape

4. Remove the hex bolts A (4) and hex bolt B (5).

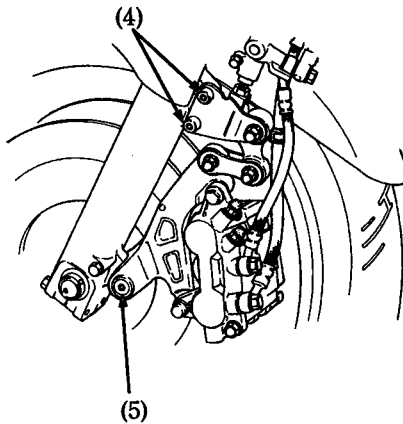

(4) Hex bolts A

(5) Hex bolt B

5. Remove the left caliper assembly (6).

NOTE:

* Do not depress the brake lever when the wheel is off the motorcycle. The caliper pistons will be forced out of the cylinders with subsequent loss of brake fluid. If this occurs, servicing of the brake system will be necessary. See your authorized Honda dealer for this service.

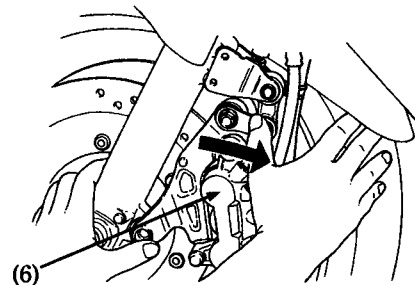

(6) Left caliper assembly

6. Loosen the right and left axle pinch bolts (7), and remove the axle bolt (9).
7. Withdraw the front axle (8) and remove the front wheel.

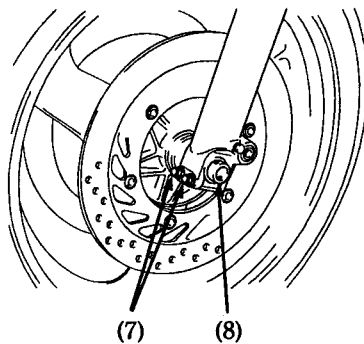

(7) Axle pinch bolt

(8) Front axle

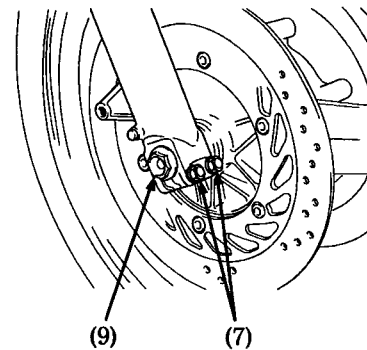

(9) Axle bolt

Installation Notes:

To install the front wheel assembly, position the wheel between the fork legs. Insert the front axle from the left side, through the left front fork leg and wheel hub.

CAUTION:

*** When installing the wheel carefully, fit the brake disc between the brake pads to avoid damaging the pads.**

Tighten the axle bolt to the specified torque.

Front axle torque :

59 N·m (5.9 kg-m , 43 lb-ft)

Fit the caliper over the disc, taking care not to damage the brake pads. Install the caliper fixing bolts and tighten to a torque of:

27 N·m (2.7 kg-m , 20 lb-ft)

Hex bolts (4),(5) torque :

27 N·m (2.7 kg-m , 20 lb-ft)

CAUTION:

*** After installation, operate the brake lever and brake pedal and check the brake operation.**

Measure the clearance (10) between each surface of the left brake disc (11) and the left caliper holder (12) with a 0,7 mm (0,028 in) feeler gauge (13) (see illustration).

If the gauge inserts easily, tighten the right and left axle pinch bolts (7) to the specified torque.

Axle pinch bolt torque :

22 N·m (2.2 kg·m , 16 lb·ft)

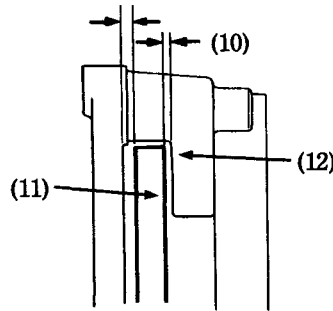

(10) Clearance
(11) Brake disc

(12) Caliper holder

▲ WARNING

* If a torque wrench was not used for installation, see your authorized Honda dealer as soon as possible to verify proper assembly. Improper assembly may lead to loss of braking capacity.

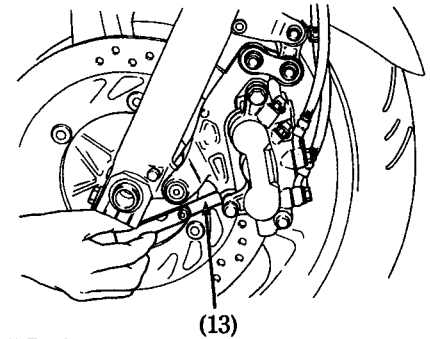

(13) Feeler gauge

If the feeler gauge cannot be inserted easily, pull the left fork outward or push inward until the gauge can be inserted and tighten the axle pinch bolts with the gauge inserted. After tightening, remove the gauge. After installing the wheel, apply the brakes several times, then recheck both discs for caliper holder to disc clearance. Do not operate the motorcycle without adequate clearance.

▲ WARNING

*** Failure to provide adequate disc to caliper holder clearance may damage the brake discs and impair braking efficiency.**

Rear Wheel Removal

1. Place the motorcycle on its center stand.
2. Loosen the drive chain adjusting nut lock nuts (1) and adjusting nuts (2).
3. Remove the rear axle nut (3).
4. Remove the drive chain (4) from the driven sprocket by pushing the rear wheel forward.
5. Remove the axle shaft (5), side collar and rear wheel from the swingarm.

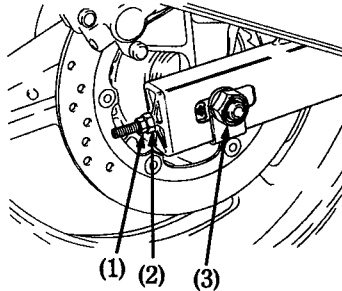

(1) Lock nuts
(2) Adjusting nuts

(3) Axle nut

NOTE:

- * Do not depress the brake pedal while the wheel is off the motorcycle. The caliper pistons will be forced out of the cylinders with subsequent loss of brake fluid. If this occurs, servicing of the brake system will be necessary. See your authorized Honda dealer for this service.

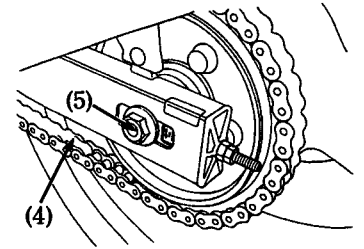

(4) Drive chain

(5) Axle shaft

Installation Notes:

- To install the rear wheel, reverse the removal procedure.
- Make sure that the lug (6) on the brake caliper is located in the slot (7) in the swingarm (8).
- Tighten the axle nut to:
93 N·m (9.3 kg·m , 67 lb·ft)
- Adjust the drive chain (Page 72).
- Apply the brake several times and check for free wheel rotation after the brake pedal is released.
- Brake system inspection (See page 89)

CAUTION:

- * When installing the wheel carefully, fit the brake disc between the brake pads to avoid damaging the pads.
- * After installation, operate the brake lever and brake pedal and check the brake operation.

▲ WARNING

- * If a torque wrench was not used for installation, see your authorized Honda dealer as soon as possible to verify proper assembly. Improper assembly may lead to loss of braking capacity.

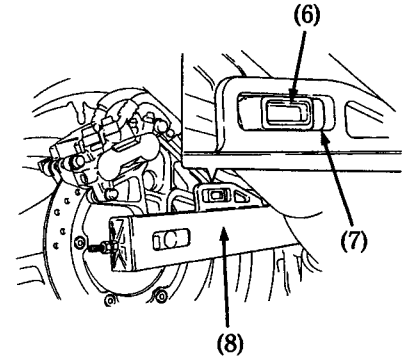

(6) Lug
(7) Slot

(8) Swing arm

BRAKE PAD WEAR

(Refer to the maintenance precautions on page 59).

Brake pad wear depends upon the severity of usage, the type of riding, and road conditions. (Generally, the pads will wear faster on wet and dirty roads.)

Inspect the pads at each regular maintenance interval (page 55).

Front/Rear Brake

Check the cutout (1) in each pad.

If either pad is worn to the cutout, replace both pads as a set. See your authorized Honda dealer for this service.

<FRONT BRAKE>

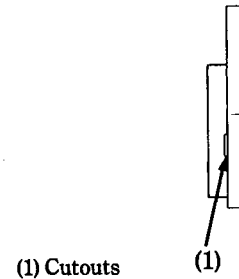
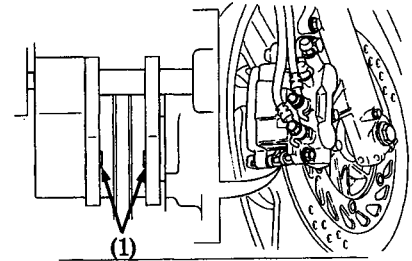

⟨REAR BRAKE⟩

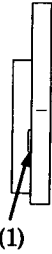
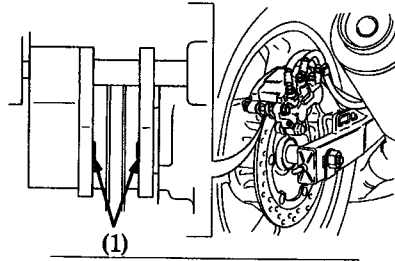

(1) Cutouts

BRAKE SYSTEM INSPECTION

(Refer to the maintenance precautions on page 59).

Check the brake system as follows:

1. Place the motorcycle on its center stand, stop the engine, and place the transmission in neutral.
2. Apply a 10 x 12 mm box end wrench (1) included in the tool kit to the left front caliper bolt (2).

3. Turn the wrench clockwise while slowly rotating the rear wheel. The brake system is normal if the rear wheel stops. If the rear wheel does not stop, see your authorized Honda dealer.

NOTE:

- * Turning the wrench counterclockwise will loosen the bolt.

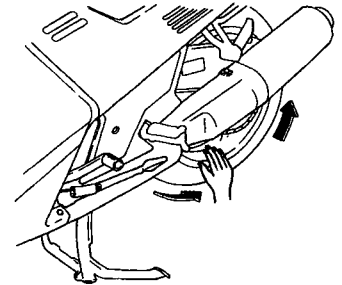
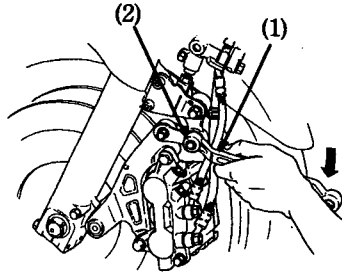

(1) 10 x 12mm box end wrench (2) Bolt

BATTERY

(Refer to the maintenance precautions on page 59).

If the motorcycle is operated with insufficient battery electrolyte, sulfation and battery plate damage will occur.

If rapid loss of electrolyte is experienced, or if your battery seems to be weak, causing slow starting or other electrical problems, see your authorized Honda dealer.

CAUTION:

- * **When checking the battery electrolyte level or adding distilled water, make sure the breather tube is connected to the battery breather outlet.**
- * **Use only distilled water in the battery. Tap water will shorten the service life of the battery.**
- * **Filling the battery above the UPPER LEVEL line may cause the electrolyte to overflow, resulting in corrosion to engine or frame parts. Immediately wash off any spilled electrolyte.**
- * **The battery breather tube must be routed as shown on the label. Do not bend or twist the breather tube. A bent or kinked breather tube may pressurize the battery and damage its case.**

▲ WARNING

- * **The battery gives off explosive gases; keep sparks, flames, and cigarettes away. Provide adequate ventilation when charging or using the battery in an enclosed space.**
- * **The battery contains sulfuric acid (electrolyte). Contact with skin or eyes may cause severe burns. Wear protective clothing and a face shield.**
 - **If electrolyte gets on your skin, flush with water.**
 - **If electrolyte gets in your eyes, flush with water for at least 15 minutes and call a physician immediately.**
- * **Electrolyte is poisonous.**
 - **If swallowed, drink large quantities of water or milk and follow with milk of magnesia or vegetable oil and call a physician.**
- * **KEEP OUT OF REACH OF CHILDREN.**

Battery electrolyte:

The battery is under the seat. Unhook the strap (1) and remove the battery cover (2).

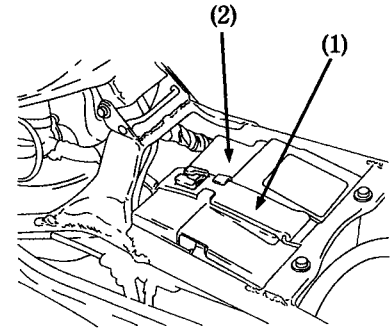

(1) Strap

(2) Cover

Remove the tool kit and pull back the separator (4).

Check the electrolyte level with the motorcycle on its center stand on level ground. The electrolyte level must be maintained between the UPPER (5) and LOWER (6) level marks on the side of the battery.

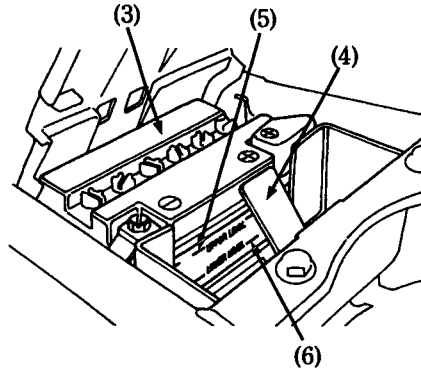

(3) Battery
(5) UPPER level

(4) Separator
(6) LOWER level

If the electrolyte level is low, disconnect the negative (-) terminal lead (7) from the battery first, then disconnect the positive (+) terminal lead (8).

Disconnect the battery breather tube (9). Pull out the battery. Remove the battery filler caps (10).

Carefully add distilled water to the UPPER level mark, using a small syringe or plastic funnel.

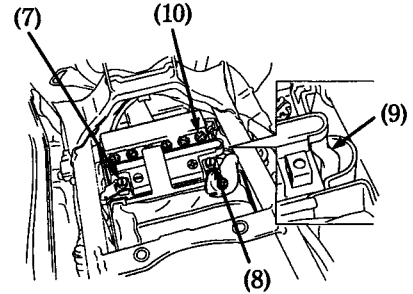

(7) Negative terminal lead

(8) Positive terminal lead

(9) Breather tube

(10) Filler caps

FUSE REPLACEMENT

(Refer to the maintenance precautions on page 59).

The main fuse (1), located near the rear brake reservoir behind the right side cover is :

30A (Main fuse)

The spare main fuse (3) is located on battery strap.

The fuse box (4) is located under the left inner cover. The specified fuses are :

10A and 20A

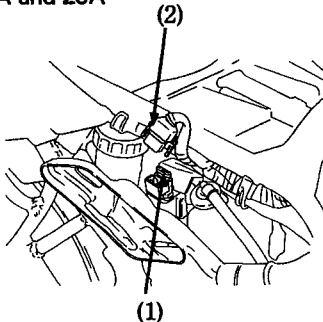

(1) Main fuse

(2) Wire connector

When frequent fuse failure occurs, it usually indicates a short circuit or an overload in the electrical system. See your authorized Honda dealer for repair.

CAUTION:

*** Turn the ignition switch OFF before checking or replacing fuses to prevent accidental short-circuiting.**

To replace the main fuse (1), remove the seat and right side cover (page 40), disconnect the wire connector (2) of the stator magnetic switch and pull out the old fuse. Install a new fuse and reconnect the connector.

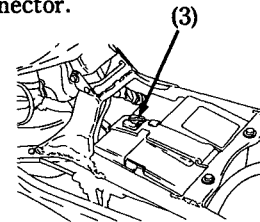

(3) Spare main fuse

To replace any fuses in the fuse box (4), remove the hex bolt (5) and left inner cover (6). Then open the fuse box cover (7). Spare fuses (8) are located in the fuse box. Pull the old fuse out of the clips. Push a new fuse into the clips and close the fuse box cover. Install the left inner cover and tighten the hex bolt.

▲ WARNING

*** Never use a fuse with a different rating from that specified. Serious damage to the electrical system or a fire may result, causing a dangerous loss of lights or engine power.**

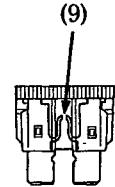
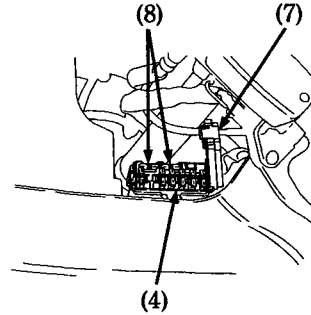
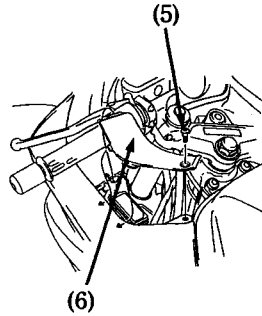

(4) Fuse box

(5) Hex bolt

(6) Left inner cover

(7) Fuse box cover

(8) Spare fuses

(9) Blown fuse

STOPLIGHT SWITCH ADJUSTMENT

(Refer to the maintenance precautions on page 59).

Check the operation of the stoplight switch (1) behind the right lower cover from time to time.

Adjustment is done by turning the adjusting nut (2). Turn the nut in the direction (A) if the switch operates too late and in direction (B) if the switch operates too soon.

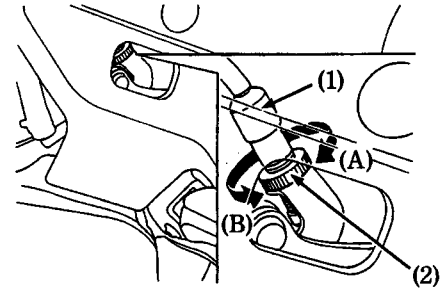

- (1) Stoplight switch
- (2) Adjusting nut

BULB REPLACEMENT

(Refer to the maintenance precautions on page 59).

Headlight/Position Light Bulb

▲ WARNING

- * **The light bulb becomes very hot while the light is ON, and remain hot for a while after it is turned OFF. Be sure to let it cool down before servicing.**

CAUTION:

- * **Wear clean gloves while replacing the bulb.**
- * **Do not put finger prints on the headlight bulb, as they may create hot spots on the bulb and cause it to break.**
- * **If you touch the bulb with your bare hands, clean it with a cloth moistened with alcohol to prevent its early failure.**

NOTE:

- * **Be sure to turn the ignition switch OFF when replacing the bulb.**

Except Italian

1. Remove the lid (See page 41).
2. Pull off the socket (1) without turning.
3. Remove the seat rubber (2).
4. Unhook the bulb retainer (3) and pull out the headlight bulb (4) without turning.
5. Install a new bulb in the reverse order of removal.

NOTE:

- * Install the dust cover with its "TOP" mark facing up.
- * Do not use bulbs other than that specified.
- * After installing a new bulb, check that the light operates properly.

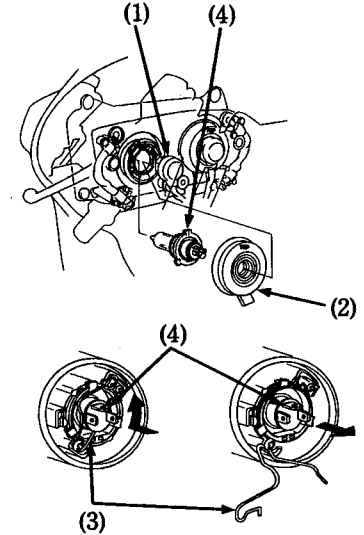

(1) Socket
(3) Bulb retainer

(2) Seat rubber
(4) Headlight bulb

Italian only

1. Remove the socket (1) by pulling it upward.
2. Slightly press down on the bulb (2) and turn it counterclockwise.
3. Install a new bulb (2).
4. Align the tab (3) of the socket with the hole in the headlight case (4) and press the socket into place on the headlight case securely.

NOTE:

- * Do not use bulbs other than that specified.
- * After installing a new bulb, check that the light operates properly.

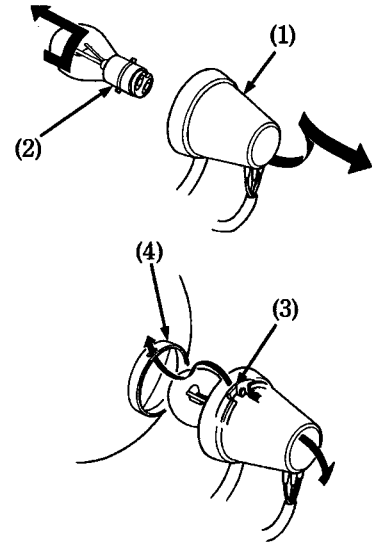

(1) Socket
(3) Tab

(2) Bulb
(4) Headlight case

Stop/Taillight Bulb

▲ WARNING

- * **The light bulb becomes very hot while the light is ON, and remain hot for a while after it is turned OFF. Be sure to let it cool down before servicing.**

CAUTION:

- * **Wear clean gloves while replacing the bulb.**
- * **If you touch the bulb with your bare hands, clean it with a cloth moistened with alcohol to prevent its early failure.**

NOTE:

- * **Be sure to turn the ignition switch OFF when replacing the bulb.**

1. Remove the rear seat (page 38).
2. Turn the socket (1) 90° counterclockwise, then pull it out toward you.
3. Slightly press down on the bulb (2) and turn it counterclockwise.
4. Install a new bulb in the reverse order of removal.

NOTE:

- * **Do not use bulbs other than that specified.**
- * **After installing a new bulb, check that the light operates properly.**

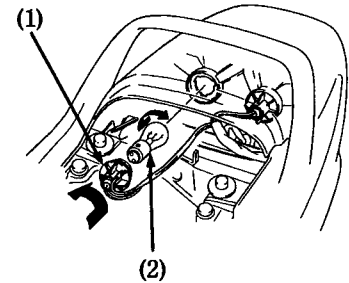

(1) Socket

(2) Bulb

Front/Rear Turn Signal Bulb

▲ WARNING

- * **The light bulb becomes very hot while the light is ON, and remain hot for a while after it is turned OFF. Be sure to let it cool down before servicing.**

CAUTION:

- * **Wear clean gloves while replacing the bulb.**
- * **If you touch the bulb with your bare hands, clean it with a cloth moistened with alcohol to prevent its early failure.**

NOTE:

- * **Be sure to turn the ignition switch OFF when replacing the bulb.**

<FRONT>

1. Remove the lid (page 41).
2. Turn the socket (1) 90° counterclockwise, then pull it out toward you.
3. Slightly press down on the bulb (2) and turn it counterclockwise.
4. Install a new bulb in the reverse order of removal.

NOTE:

- * **Do not use bulbs other than that specified.**
- * **After installing a new bulb, check that the light operates properly.**

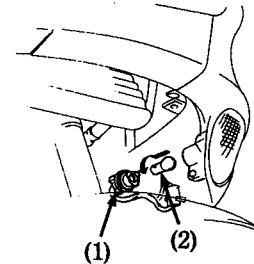

(1) Socket

(2) Bulb

<REAR>

1. Remove the turn signal lens from the turn signal by removing the screw (1).
2. Slightly press in on the bulb (2) and turn in 90° counterclockwise. Remove the bulb.
3. Install a new bulb in the reverse order of removal.

NOTE:

- * Do not use bulbs other than that specified.
- * After installing a new bulb, check that the light operates properly.

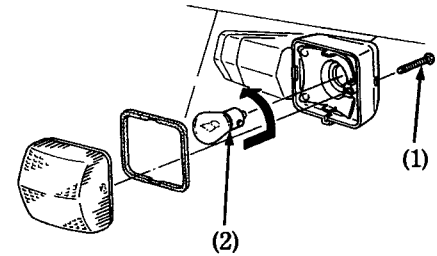

(1) Screw

(2) Bulb

CLEANING

Clean your motorcycle regularly to protect the surface finishes and inspect for damage, wear, and oil, coolant or brake fluid leakage.

CAUTION:

*** High pressure water (or air) can damage certain parts of the motorcycle.**

Avoid spraying high pressure water (typical in coin-operated car washes) at the following areas:

- Wheel Hubs
- Ignition Switch
- Carburetors
- Clutch Master Cylinder
- Brake Master Cylinders
- Instruments
- Handlebar Switches
- Muffler Outlets
- Under Fuel Tank
- Drive Chain
- Under Seat

1. After cleaning, rinse the motorcycle thoroughly with plenty of clean water. Strong detergent residue can corrode alloy parts.

NOTE:

*** Clean the fairing and other plastic parts using a cloth or sponge dampened with a solution of mild detergent and water. Rub the soiled area gently rinsing it frequently with fresh water.**

2. Dry the motorcycle, start the engine, and let it run for several minutes.

▲ WARNING

*** Braking efficiency may be temporarily impaired immediately after washing the motorcycle. Anticipate longer stopping distance to avoid a possible accident.**

3. Test the brakes before riding the motorcycle. Several applications may be necessary to restore normal braking performance.
4. Lubricate the drive chain immediately after washing and drying the motorcycle.

Aluminum Wheel Maintenance

Aluminum corrodes when it comes in contact with dust, mud, road salt, etc. After riding, clean the wheels with a wet sponge and mild detergent, then rinse well with water and wipe dry with a clean cloth.

CAUTION:

- * **Do not use steel wool or a cleaner containing abrasives or compounds to clean the wheels, as they can cause damage.**
- * **Do not ride over a curb or rub the wheel against an obstacle, as wheel damage may result.**

STORAGE GUIDE

Extended storage, such as for winter, requires that you take certain steps to reduce the effects of deterioration from non-use of the motorcycle. In addition, necessary repairs should be made **BEFORE** storing the motorcycle; otherwise, these repairs may be forgotten by the time the motorcycle is removed from storage.

STORAGE

1. Change the engine oil and filter.
2. Lubricate the drive chain (page 76).
3. Make sure the cooling system is filled with a 50/50% antifreeze solution.
4. Drain the fuel tank and carburetors into an approved petrol container. Spray the inside of the tank with an aerosol rust-inhibiting oil.

Reinstall the fuel cap on the tank.

NOTE:

- * If storage will last more than one month, carburetor draining is very important, to assure proper performance after storage.

▲ WARNING

- * **Petrol is extremely flammable and is explosive under certain conditions. Perform this operation in a well-ventilated area with the engine stopped. Do not smoke or allow flames or sparks in the area where petrol is drained or stored and where the fuel tank is refueled.**

5. Remove the spark plugs and pour a tablespoon (15–20 cc) of clean engine oil into each cylinder. Crank the engine several times to distribute the oil, then reinstall the spark plugs.

NOTE:

- * When turning the engine over, the engine Stop Switch should be OFF and each spark plug placed in its cable cap and grounded to prevent damage to the ignition system.

6. Remove the battery. Store in an area protected from freezing temperatures and direct sunlight. Check the electrolyte level and slow charge the battery once a month.
7. Wash and dry the motorcycle. Wax all painted surfaces. Coat chrome with rustinhibiting oil.
8. Inflate the tyres to their recommended pressures. Place the motorcycle on blocks to raise both tyres off the ground.
9. Cover the motorcycle (don't use plastic or other coated materials) and store in an unheated area, free of dampness with a minimum of daily temperature variation. Do not store the motorcycle in direct sunlight.

REMOVAL FROM STORAGE

1. Uncover and clean the motorcycle.
Change the engine oil if more than 4 months have passed since the start of storage.
2. Check the battery electrolyte level and charge the battery as required. Install the battery.
3. Drain any excess aerosol rust-inhibiting oil from the fuel tank. Fill the fuel tank with fresh petrol.
4. Perform all Pre-ride Inspection checks (page 43).
Test ride the motorcycle at low speeds in a safe riding area away from traffic.

NOISE CONTROL SYSTEM (AUSTRALIA ONLY)

TAMPERING WITH THE NOISE CONTROL SYSTEM IS PROHIBITED: Owners are warned that the law may prohibit : (a) The removal or rendering inoperative by any person other than for purposes of maintenance, repair, or replacement, of any device or element of design incorporated into any new vehicle for the purpose of noise control prior to its sale or delivery to the ultimate purchaser or while it is in use; and (b) the use of the vehicle after such device or element of design has been removed or rendered inoperative by any person.

SPECIFICATIONS

DIMENSIONS

Overall length

2,235 mm (88.0 in) ··· F, IT, ED, E, SP, U

2,270 mm (89.4 in) ··· G, AR, SW, ND

Overall width

740 mm (29.1 in)

Overall height

1,215 mm (47.8 in)

Wheel base

1,500 mm (59.1 in)

WEIGHT

Dry weight

235 kg (518 lbs) (Except SW, AR)

236 kg (520 lbs) (SW, AR only)

CAPACITIES

Engine oil (After draining and
oil filter change)
(After disassembly)

3.8 ℓ (4.0 US qt , 3.3 Imp qt)

Fuel tank

4.5 ℓ (4.8 US qt , 4.0 Imp qt)

Fuel reserve

22.0 ℓ (5.81 US gal , 4.84 Imp gal)

Cooling system capacity

3.5 ℓ (0.92 US gal , 0.77 Imp gal)

Passenger capacity load

2.8 ℓ (0.74 US gal , 0.62 Imp gal)

Maximum weight capacity

Operator and one passenger

185 kg (408 lbs)

ENGINE

Bore and stroke
Compression ratio
Displacement
Spark plug
Standard

Spark plug gap
Idle speed

77.0 x 53.6 mm (3.03 x 2.11 in)
10.5 : 1
998 cm³ (60.9 cu-in)

DPR9EA-9 (NGK) or
X27EPR-U9 (NIPPONDENSO)
0.80-0.90 mm (0.031-0.035 in)
1,000±100 rpm (Except SW,AR)
1,050±50 rpm (SW only)
1,050±100 rpm (AR only)

CHASSIS AND SUSPENSION

Caster	27°
Trail	110 mm (4.3 in)
Tyre size, front	120/70 VR17—V270
Tyre size, rear	170/60 VR17—V270

POWER TRANSMISSION

Primary reduction	1.785
Gear ratio, 1st	2.750
2nd	2.066
3rd	1.647
4th	1.368
5th	1.173
6th	1.045
Final reduction	2.470 (Except AR)
	2.412 (AR only)

ELECTRICAL

Battery
Generator

12V—14AH
AC Generator

LIGHTS

Headlight (HIGH/LOW)

12V—60/55W x 2 ... E
12V—60/55W , 12V—60W (Except E, IT, U)
12V—45/45W x 2 ... U
12V—60/55W ... IT

Position light

12V—5W (Except U)

Tail/brake light

12V—5/21W x 2

Turn signal light Front
 Rear

12V—21W x 2

12V—21W x 2

Instrument lights

12V—1.7W x 4

Neutral indicator

12V—3.4W

Turn signal indicator

12V—3.4W x 2

High beam indicator

12V—3.4W

Low oil pressure indicator

12V—3.4W

Side stand indicator

12V—3.4W

FUSE

10A ,20A
30A (Main fuse)